

# 62 GB- Series

Miniature Bayonet Lock Connectors  
MIL-C-26482

# CE-2a

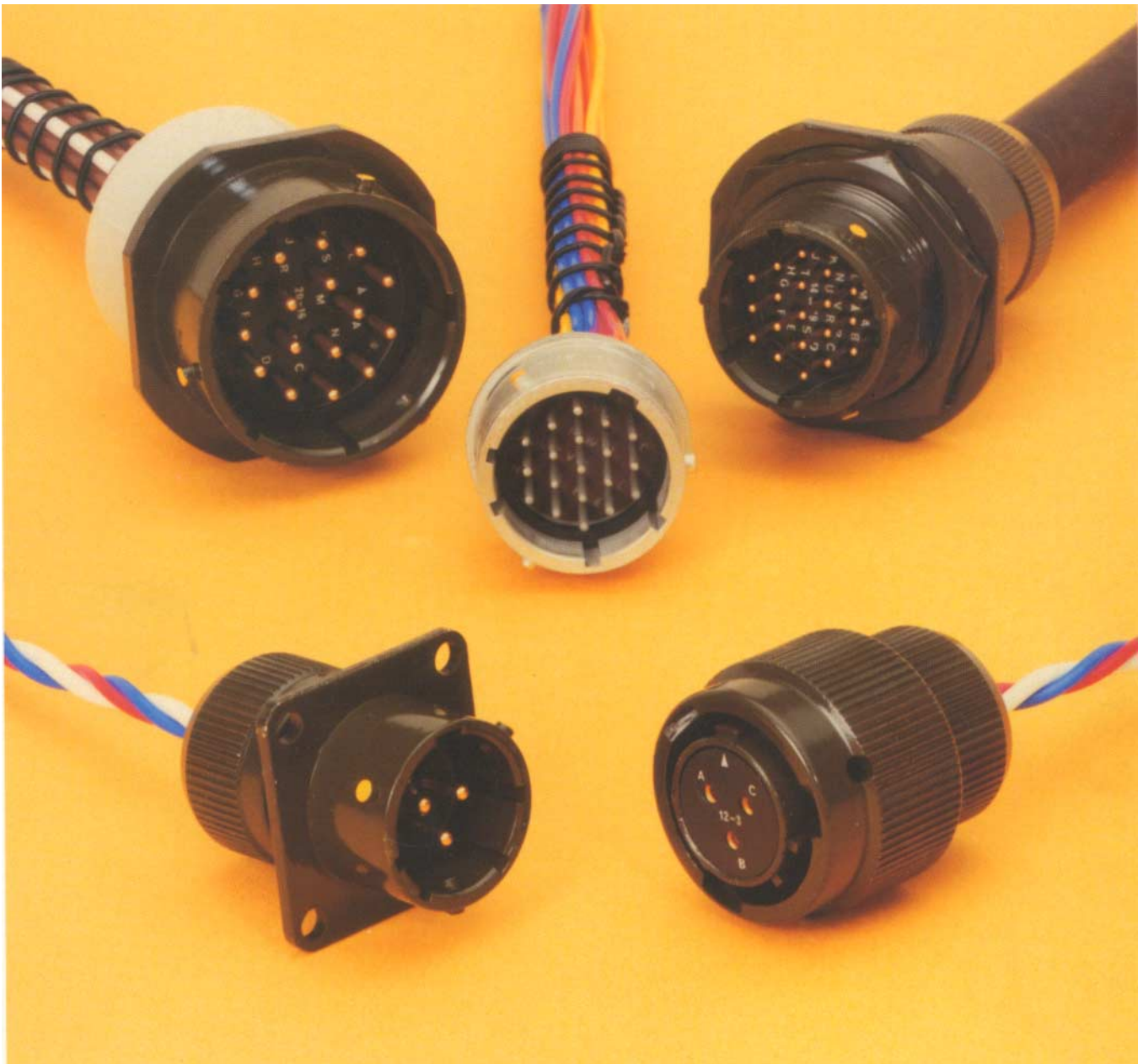

This miniature bayonet lock connector series offers designers important features not found in any other range of connectors.

They are developed and manufactured entirely in the U.K. by AMPHENOL Ltd., and have full qualification approval to British Standards Specification BS 9522 F0017 and British Defence Specification DEF STAN 59-35 (Part 3) Sec. 7.

# Amphenol

# 62GB and Pattern 608 New Planforms

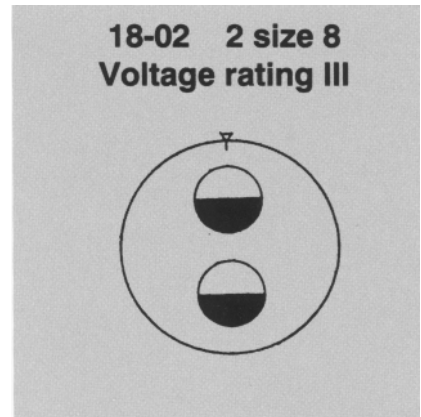
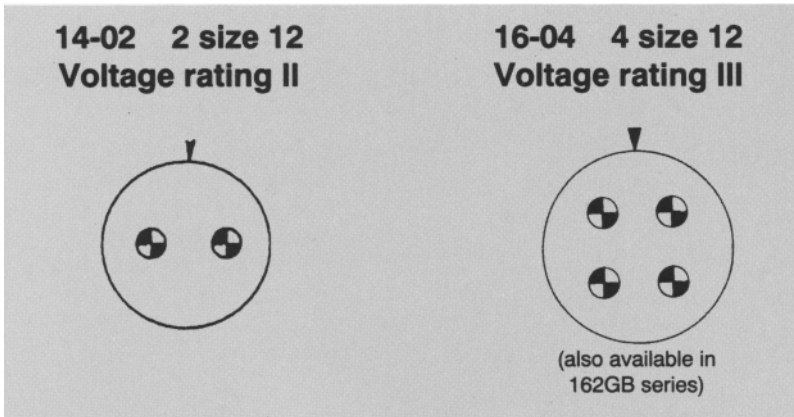

**Current:**

- (a) Maximum current per individual contact (in isolation)\* at ambient temperature of 85°C  
Contact size 12: 23 A
- (b) Maximum current per contact through all contacts simultaneously at an ambient temperature of 85°C  
Contact size 12: 20 A

**Current:**

- (a) Maximum current per individual contact (in isolation)\* at ambient temperature of 85°C  
Contact size 8: 45 A
- (b) Maximum current per contact through all contacts simultaneously at an ambient temperature of 85°C  
Contact size 8: 40 A

	Sea level 1013 mbar †			8500m (27,900ft) 320 mbar			21,340m (70,000ft) 44 mbar		
	I	II	III	I	II	III	I	II	III
Voltage rating									
Working voltages ** (nominal)	700	1200	1500	550	650	800	330	380	450
d.c. or a.c. peak Voltage proof	2100	3000	3000	1100	1300	1300	660	760	750
d.c. or a.c. peak									

\* i.e. when only one contact per connector is electrically loaded.  
 † 1 mbar=10<sup>2</sup> N/m<sup>2</sup>=100 Pa  
 \*\* Establishment of electrical safety factors is the responsibility of the user

## **CONTENTS**

## **Page**

Amphenol 62GB Solder Connectors	1
Schedule of Tests	2-3
Connector Styles Available	4-5
Insert Availability	6-7
Ordering 62GB Series Connectors	8-9
Box Mounting Receptacles - Table of Styles	10-11
Box Mounting Receptacles	12-16
Single Hole Fixing Receptacles - Table of Styles	17-19
Single Hole Fixing Receptacles	20-27
Cable Mounting Receptacles - Table of Styles	28
Cable Mounting Receptacles	29-31
Plugs - Table of Styles	32-33
Plugs	34-39
Accessories - Table of Styles	40-41
Accessories	42-48
Cable Accessories - Table of Styles	49-50
Cable Accessories	51-55
Insert Orientations	56
Key/Keyway Orientations	57
Assembly Instructions	58-61
Wire Stripping	62
Torque Details	62

# Amphenol® 62GB solder connectors

This miniature bayonet lock connector series offers designers important features not found in any other range of connectors. The range has full qualification approval to British Standards Specification BS 9522 FOO 17 and British Defence Specification DEF STAN 59-35 (Part 3) Sec. 7.

62GB Series connectors - developed and manufactured entirely in the United Kingdom by Amphenol Limited, also have M.O.D. certified qualification approval to the United States Military Specification MIL-C-26482E on certificate No. 1713. They are the first and only British connectors to have achieved this. A doubly strong position which Amphenol are well geared to handle. The manufacturing facilities of the Whitstable plant have been cited as exemplary in Europe. Certainly the layout is extensive and extremely efficient; safety awards have been attained every time returns have been submitted to the British Safety Council.

62GB Series connectors have been well established with Government authorities on an international scale and users can be found in Sweden, Denmark, Norway, Finland, Germany, Spain, Holland, India, Canada and Italy.

## Derating

Connectors must be derated under the following operating conditions:

1. At elevated ambient temperatures, the current ratings are reduced so that total maximum hot spot temperature of 125°C is not exceeded.
2. At high altitudes, revised voltage ratings become effective as shown on page 7.
3. When connectors to different specifications are intermated (e.g. BS 9522 FOO 17 and MIL-C-26482), the combination must not be operated under conditions more severe than the less stringent clause of either specification.

Amphenol 62GB connectors are designed to meet the most stringent requirements of both specifications.

## Military Specifications

British Standards Specification BS 9522 FOO 17 closely corresponds to the United States Military Specification MIL-C-26482 solder terminations. Certain differences exist between the schedules which can be seen on pages 2 and 3.

Approved gauges are used to check interchangeability of 62GB series with other connectors manufactured to BS 9522 FOO 17 or MIL-C-26482.

## Basic Construction

Connector shells are machined from solid aluminium bar stock - not forged or extruded as in competitive designs. Machining has inherent advantages in terms of strength and adaptability. 62GB Series can be supplied in brass or stainless steel, for instance.

The normal shell finish used, which has a high resistance to corrosion, is zinc cobalt olive drab. Other finishes may be supplied to special order, such as cadmium plate which is available by adding deviation (714) to the end of part number.

Inserts are of poly chloroprene rubber compounded to an Amphenol specification. Operating temperature range is -55°C to 125°C, and the connectors have gold-plated contacts designed for soldered connections. Configurations for size 20 contacts range between 2 contacts in the size 8 12.7mm (0.5in diameter) shell up to a maximum of 61 contacts in the size 2436.1 mm (1.5in diameter) shell. Intermediate sizes, and contact data for heavier current ratings are shown in the insert availability chart on page 6 and 7.

Hermetic connectors with glass sealed dielectric are manufactured with mild steel shells and nickel iron contacts plated tin over copper.

\* Other finishes are available on request.

## Protection Against Mis-Mating or Cross-Plugging

In BS 9522 FOO 17 positive shell-to-shell keying is provided with keys and keyways in a choice of either the normal (N) or any of the four preferred alternate positions: B, C, E and F. This prevents mismating between shells of different orientations and overcomes the difficulties associated with rotated inserts and a standard key-keyway orientation. In the latter system, damage to the inserts or contacts can result if excessive force is used to engage non-mating pairs.

Rotated inserts are, however, permissible in BS 9522 FOO 17 connectors if required to mate with or replace units to MIL-C-26482 mounted in existing equipment. Connectors have normal orientations manufactured to BS 9522 FOO 17 or MIL-C-26482 are fully intermateable as also are connectors with inserts in positions W, X, Y or Z.

# Schedule of Tests Required for Qualification Approval

Tests	Brief Description
<b>Visual Examination</b>	
<b>Dimensions, outline mass(including contacts) Compatability Gauging procedure</b>	
<b>Polarization</b>	
<b>Engaging and separating force, connector</b>	Engagement max: 0,90 Nm (8.0 lbf.in.) to 4,97 Nm (44 lbf.in.) according to shell size. Separation min: 0,22 Nm (2.0 lbf.in.) to 1,58 Nm (14.0 lbf.in.) according to shell size.
<b>Contact Holding Force</b>	0,21 N (0.047 lbf) min.size 20 0,56 N (0.126 lbf)min. size 16
<b>Sealing (air pressure)</b>	Max leakage 28,53 uNm/s (1 cm3/h), 1 bar (14.5 p.s.i.) differential.
<b>Sealing Hermetic</b>	Hermetic receptacles have a max leak of 0.1 micron cubic foot per hour (1 x 10 <sup>-6</sup> Cm3/s)
<b>Contact Resistance</b>	5 milliohms max.
<b>Housing (Shell) Continuity</b>	200 milliohms max. 5 milliohms max. grounding spring styles.
<b>Insulation Resistance</b>	5,000 Megaohms at 500 - 50 V d.c.
<b>Voltage Proof</b>	See page 7. Duration 1 minute
<b>Soldering</b>	As BS 9520: 1974, Clause 1.2.6.6, Method 2.
<b>Bumping</b>	As BS 9520: 1974, Clause 1.2.6.1. 4,000 -10 bumps / 390m / s2 (40 gn).
<b>Vibration</b>	As BS 9520: 1974, Clause 1.2.6.2.1. Procedure A. 10 Hz to 5000 Hz, 0.75 mm / 10 gn.
<b>Shock</b>	As BS 9520: 1974, Clause 1.2.6.3. 981 m/s2 (100 g n).
<b>Acceleration (Steady State)</b>	As BS 9520: 1974, Clause 1.2.6.4. 490 m/s2 (50 gn).
<b>Rapid Change of Temperature</b>	As BS 9520: 1974, Clause 1.2.6.7. -550 C to - 1250 C.
<b>Climatic Sequence</b>	As BS 9520: 1974, Clause 1.2.6.11. Severity 55/125/56.
<b>Flammability</b>	As BS 9520: 1974, Clause 1.2.6.8. Direct flame applied, duration 1 minute.
<b>Damp Heat (Steady State)</b>	As BS 9520: 1974, Clause 1.2.6.14. Severity 56 days.

# Schedules of Tests Required for Qualification Approval

Tests	Brief Description
<b>Immersion (at low air pressure)</b>	3 cycles at 30 mins each cycle, total immersion in water at pressure 44 m bar.
<b>Mechanical Endurance</b>	500 operations minimum
<b>High Temperature Endurance</b>	Long term: 1,000 hrs. at 850 C ambient carrying the specified current. Short term: 250 hrs at 1250 C, no current.
<b>Mould Growth</b>	As BS 9520: 1974, Clause 1.2.6.15. 28 days duration.
<b>Salt Mist</b>	As BS 9520: 1974, Clause 1.2.6.16. Severity 1.
<b>Dust</b>	As BS 9520: 1974, Clause 1.2.6.17. Exposure 30 minutes.
<b>Robustness of Terminations</b>	44,5 N (101bf) size 16 22,2 N (5 lbf) size 20
<b>Contact Retention (in insert)</b>	67,0 N (15 lbf) min. size 20 112,0 N (25 lbf) min. size 16
<b>Insert Retention (in shell)</b>	517 KN1m2 (751bf/in2) min.
<b>Test Prod Damage</b>	Moment: 0,056 Nm (0.5 lbf in) size 20 0,225 Nm (2 lbf in) size 16
<b>Impact</b>	Five impacts, drop height 1 m (3ft.3 in.).
<b>Grounding Spring Holding Force Plugs with grounding springs only.</b>	1,17 N (0.263 lbf) to 2,74 N (0.616 lbf) according to size.
<b>Fluid Resistance</b>	Immersion in 4 solvents and 9 fluids including aircraft fuels, lubricating oils and hydraulic fluids.
<b>Compass Safe Distance</b>	As BS 9520: 1974, Clause 1.2.5.11. 127 mm (5.0 in) min.

# Connector Styles Available

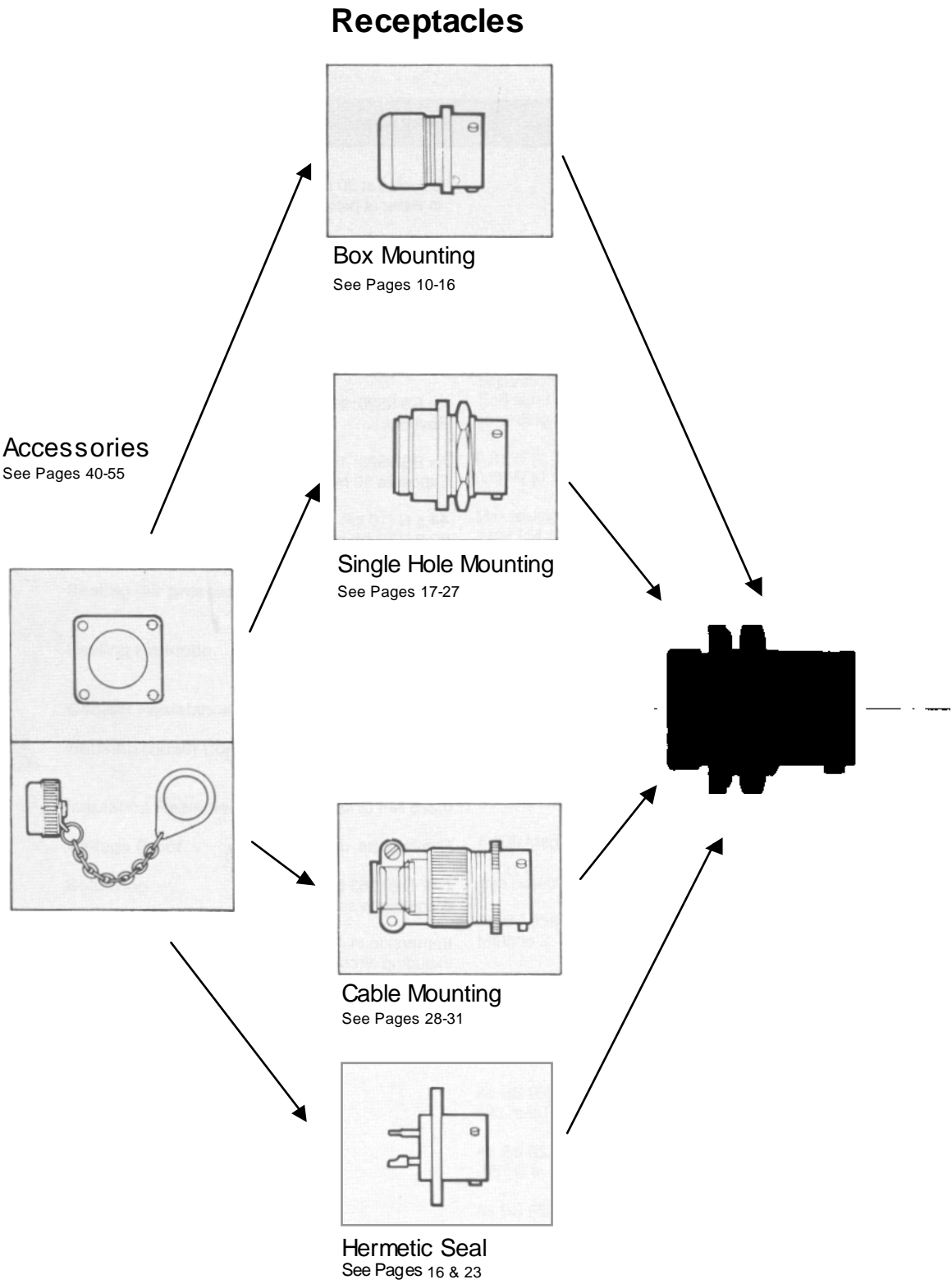

# Connector Styles Available

## Plugs

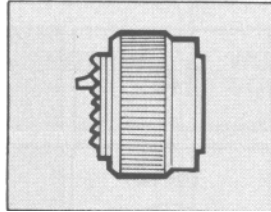

**Straight Plug**  
See Pages 34-37

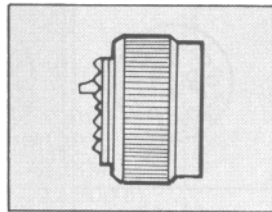

**Grounded Plug**  
See Page 34

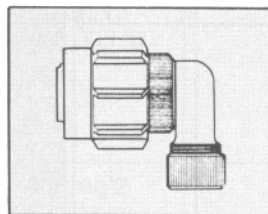

**Audio Plug**  
See Page 38

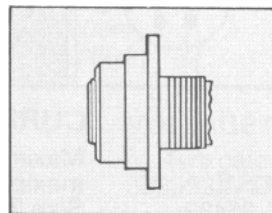

**Push on - Pull off**  
See Page 39

## Accessories

See Pages 40-55

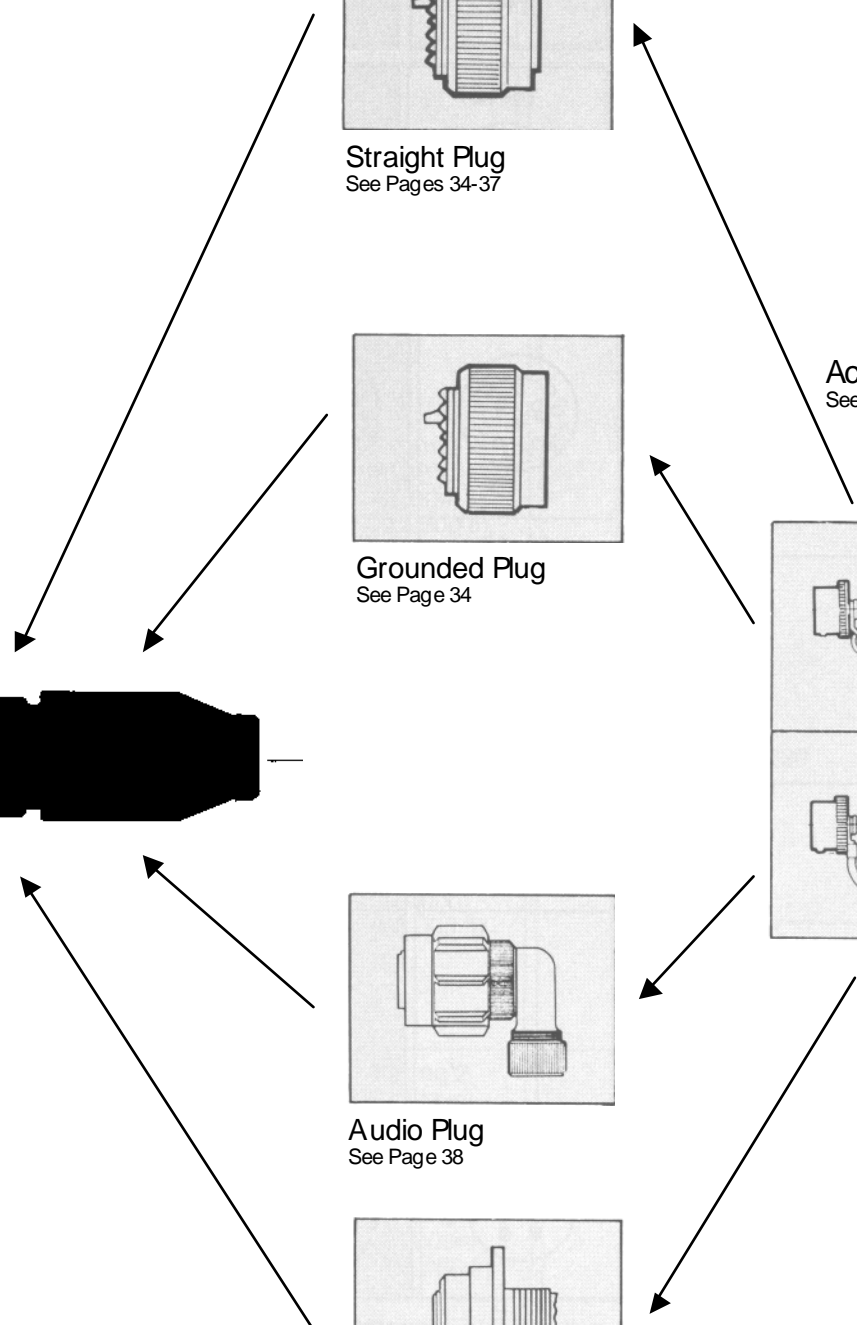
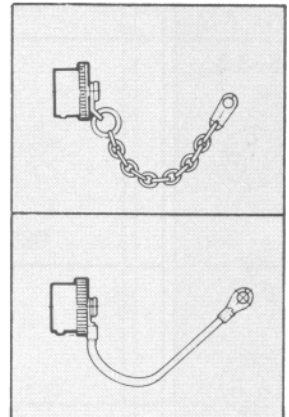



# Insert Availability

8	10	12	14	16	18	20
<b>8-2*</b> 	<b>10-6</b> 	<b>12-10</b> 	<b>14-12†</b> 	<b>16-23*</b> 	<b>18-32</b> 	<b>20-41</b> 
<b>8-3*</b> 	<b>10-7</b> 		<b>14-15</b> 	<b>16-26</b> 		
<b>8-3 3</b> 			<b>14-19</b> 			
<b>8-4*</b> 						
<b>8-98</b> 	<b>10-2</b> 	<b>12-3</b> 	<b>14-5</b> 	<b>16-8</b> 	<b>18-11</b> 	<b>20-16</b> 

## NOTES

\* This insert arrangement is not included in B.S. spec., but is available and listed in MIL-C-26482.

† Due to the arrangement of contacts in the 14-12 insert arrangement it is classified, for current derating, in the shell size range 18-24.

Lettering of inserts shown above corresponds to view of front (mating surface of pin inserts or rear face (cable accessory end) of socket inserts).

KEY ● No 16 size contacts  
○ No 20 size contacts

## CURRENT RATING

Maximum current per individual contact (in isolation) at a maximum ambient temperature of 85°C: Size 20 contact 7.5A Size 16 contact 13-0A The performance of 62GB Series connectors at all times exceeds the maximum continuous bunched rating of the appropriate size wire, or cable of equivalent temperature rating. This bunched rating is therefore the determining factor. In the case of mixed loadings, the greatest individual load shall be the bunched loading. In any combination of ambient temperature plus temperature rise due to current flow through the contacts, the maximum connector internal hot spot temperature of 125°C must not be exceeded.

That is, when only one contact per connector is loaded.

# Insert Availability

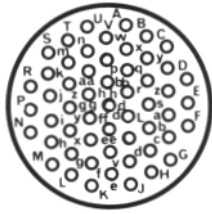
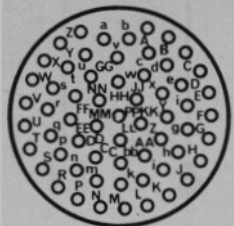
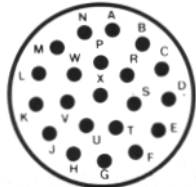
		VOLTAGE RATINGS			
22	24	ALTITUDE	D.C. WORKING VOLTAGE	AC. WORKING VOLTAGE R.M.S.	PROOF VOLTAGE D.C. OR A.C. PEAK
<p>22-55</p> 	<p>24-61</p> 	<p><b>Rating 1</b> Sea level</p> <p>300 mb at 20°C 8,500m (27,800 ft)</p> <p>44 mb at 20°C 20,000m (66,000 ft)</p>	<p>700</p> <p>550</p> <p>330</p>	<p>500</p> <p>390</p> <p>230</p>	<p>2100</p> <p>1100</p> <p>660</p>
<p>22-21</p>  <p>† Available to special order only</p>		<p><b>Rating 2</b> Sea level 300 mb at 20°C 8,500m (27,800 ft) 44 mb at 20°C 20,000m (66,000 ft)</p>	<p>120</p> <p>650</p> <p>380</p>	<p>850</p> <p>460</p> <p>270</p>	<p>3000</p> <p>1300</p> <p>760</p>

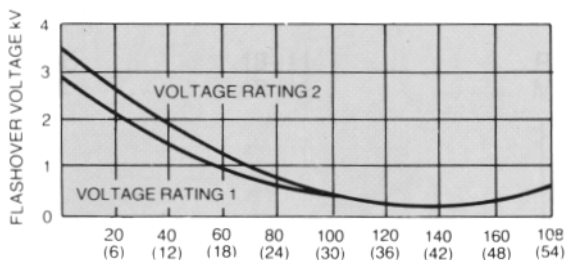

ALTITUDE-THOUSANDS OF FEET (METRES)  
Relationship between flashover voltage and altitude for each voltage rating

## VOLTAGE RATINGS

Two categories of voltage rating are specified in BS9522 F0017, F0038 and N0001.

**Rating 1** (700V d.c. working at sea-level) Applicable to the high contact density inserts shown in the upper section of the insert availability diagram above.

**Rating 2** (1200V d.c. working at sea-level) Applicable to the inserts shown in the lower section of the insert availability diagram.

**Altitude derating.** Information on voltage derating for operation at altitudes above sea-level can be obtained from the flashover voltage altitude curves on the left.

# Ordering 62GB Series Connectors

To obtain the specific connector required write down the connector number from the typical example below. Only inserts shown in the availability chart on p. 10&11 can be specified. All connectors are delivered with protective dust covers

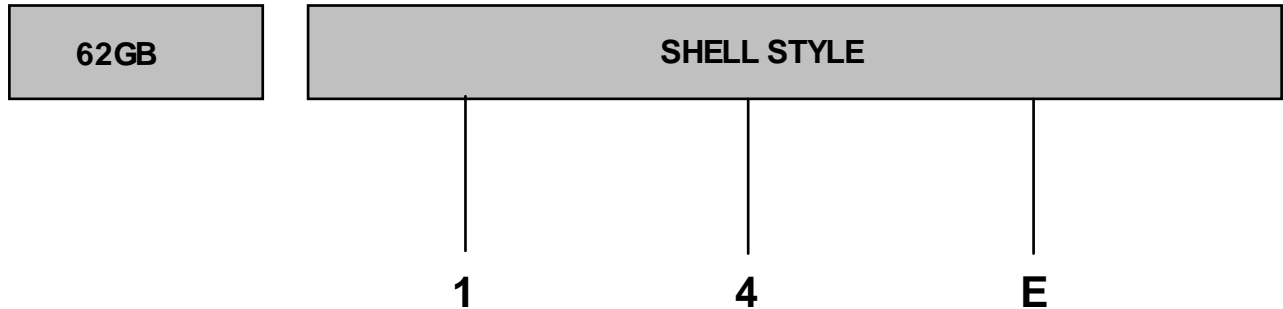

#### Series designation

62 GB - Aluminium shell  
 62 GB SS -Stainless steel shell\*  
 62 GB CU - Brass shell\*  
 \*consult factory for availability  
 62GB-XXH-Hermetic mild steel shell.

#### Specification key

1 - Styles originally specified in MIL-C-26482  
 5 - Styles exclusive to BS9522 F0017

#### Shell style

0 - Receptacle wall mounting  
 1 - Receptacle cable mounting  
 2 - Receptacle box mounting  
 3 - Receptacle, solder flange mounting  
 4 - Receptacle, internally threaded with cable accessories as illustrated, for single hole mounting  
 6 - Plug cable mounting  
 7- Receptacle, plain shell, single hole mounting

#### Environmental code

A - Plain shell, exposed solder buckets. No grommet  
 E - Insert seal and grommet seal with grommet nut (excluding 12E which has plain shell and no grommet or nut)  
 F - As (E) but grommet nut has integral strain relief clamp  
 H - Hermetic seal no cable accessories  
 J - As (E) but with resilient gland seal and nut for unscreened jacketed cable. No grommet supplied. See pp. 26-27 for accessory to accept screened jacketed cable.  
 P - Potting construction complete with potting mould  
 T - Exposed solder buckets. Threaded shell for cable accessories

## HOW TO ORDER FROM MS CONNECTOR NUMBERS

Connector numbers in the AMPHENOL and MS numbering systems. Only alternative insert orientations are specified in MIL-C-26482 which does not include alternative key/keyway orientations.

MS31	-	14	E	18 -11	P	X
62GB	-	14	E	18 -11	P	X

# Ordering 62GB Series Connectors

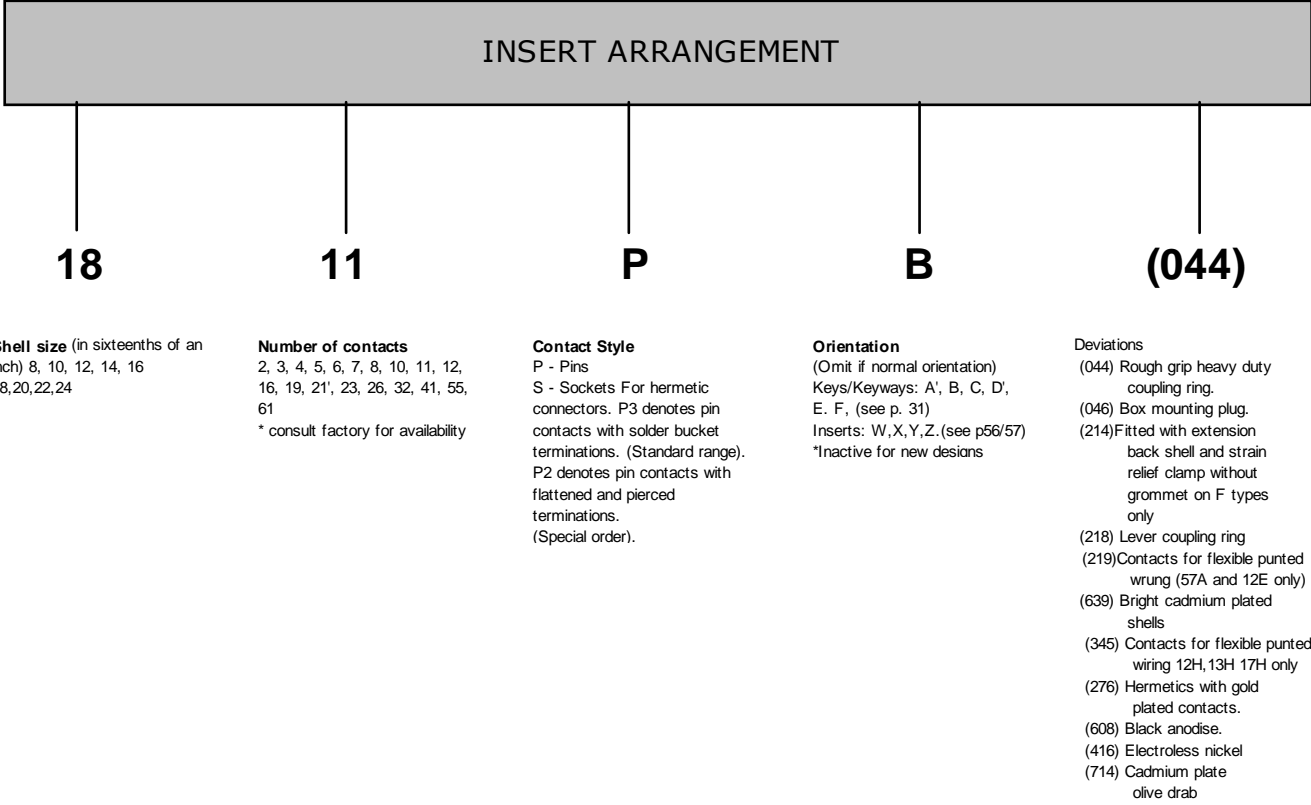

## HOW TO ORDER FROM B.S. CONNECTOR NUMBERS



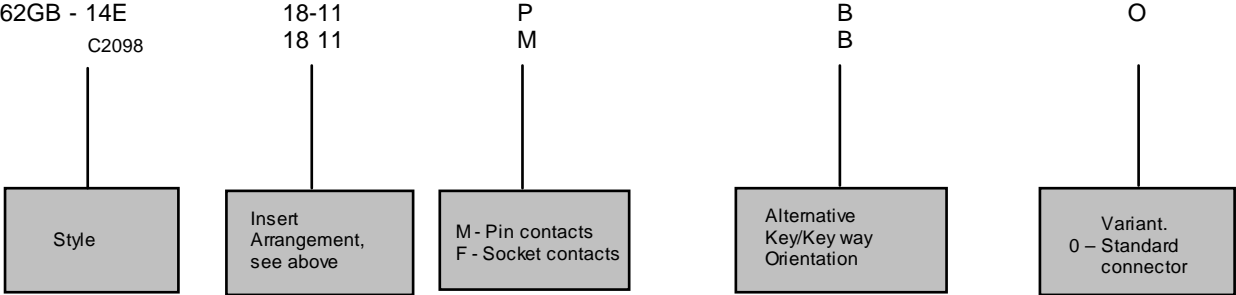





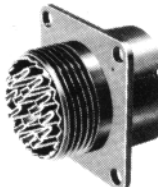

Select the connector style by reference to BS9522 F0017 using the code below for identification. Note that the B.S. Specification includes only certain connectors from the table of styles as shown on pp. 8 & 9. Alternative key/keyway orientations are preferred in the BS9522 F0017 Specification to prevent mis-mating. However, rotated inserts are permissible where connectors are required to mate with or replace items to MIL-C-26482 on existing equipment.

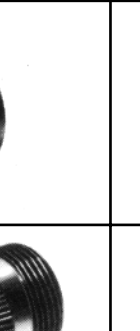

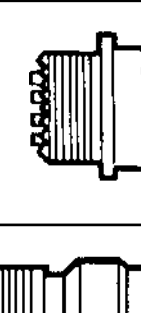
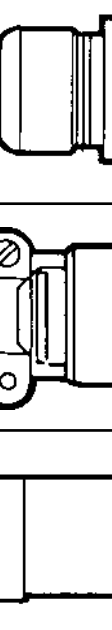
# Box Mounting Receptacles

## Table of Styles

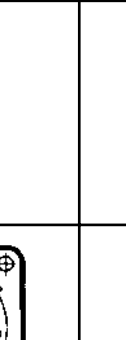
Page No.

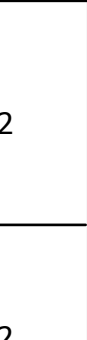
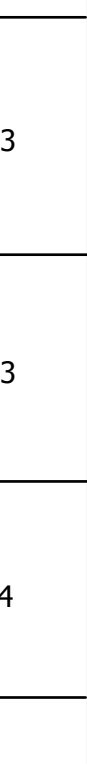
62GB-50T			12
62GB-10A			12
62GB-10E			13
62GB-10F			13
62GB-10J			14
62GB-10P			14
62GB-12E			15

# Box Mounting Receptacles

## Table of Styles

Page No.

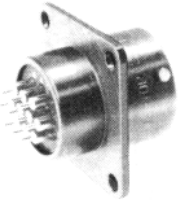
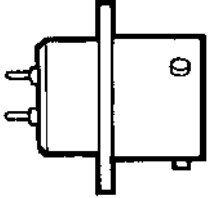
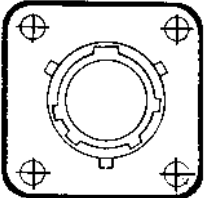
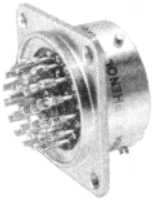
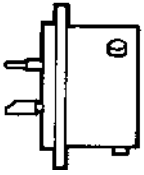
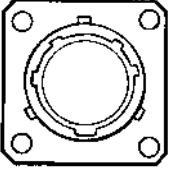
<p>62GB-12E(219)</p>				<p>15</p>
<p>62GB-12H Hermetic Seal</p>				<p>16</p>

# Box Mounting Receptacles

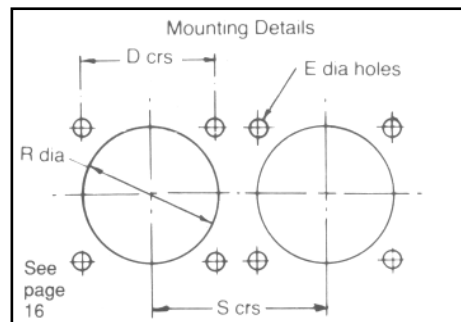

**50T**

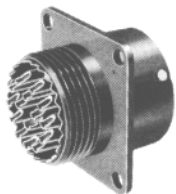

**62GB-50T**  
**BS9522-C2096**

4-hole flange mounting with threaded shell to accept standard cable accessories.

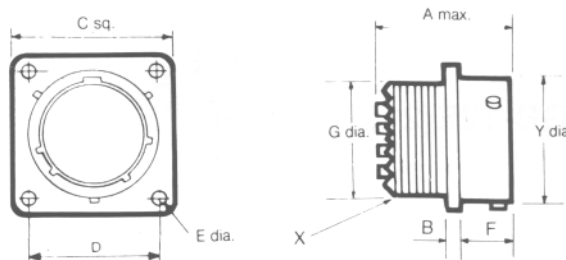

Shell Size	A max	B ± 0.005 (± 0.13)	C max sq.	D TP Sq.	E dia. ± 0.010 (± 0.254)	F ± 0.005 (± 0.13)	G dia max.	Y dia. max.	X Thread
08	0.978 24.84	0.062 1.58	0.817 20.75	0.594 15.09	0.120 3.05	0.445 11.3	0.434 11.02	0.473 12.02	7/16 - 28 UNEF
10	0.978 24.84	0.062 1.58	0.942 23.93	0.719 18.26	0.120 3.05	0.445 11.3	0.558 14.17	0.590 14.99	9/16 - 24 NEF
12	0.978 24.84	0.062 1.58	1.036 26.32	0.812 20.63	0.120 3.05	0.445 11.3	0.683 17.35	0.750 19.05	11/16 - 24 NEF
14	0.978 24.84	0.062 1.58	1.130 28.70	0.906 23.10	0.120 3.05	0.445 11.3	0.808 20.52	0.875 22.23	13/16 - 20 UNEF
16	0.978 24.84	0.062 1.58	1.223 31.07	0.969 24.61	0.120 3.05	0.445 11.3	0.933 23.7	1.000 25.4	15/16 - 20 UNEF
18	0.978 24.84	0.062 1.58	1.317 33.45	1.062 26.58	0.120 3.05	0.445 11.3	1.057 26.85	1.125 28.58	1.1/16 - 18 NEF
20	1.048 26.62	0.080 2.03	1.442 36.63	1.156 29.36	0.120 3.05	0.555 14.10	1.182 30.02	1.250 31.75	1.3/16 - 18 NEF
22	1.048 26.62	0.080 2.03	1.567 39.80	1.250 31.75	0.120 3.05	0.555 14.10	1.307 33.20	1.375 34.93	1.5/16 - 18 NEF
24	1.048 26.62	0.080 2.03	1.692 42.98	1.375 34.93	0.147 3.73	0.590 14.99	1.432 36.37	1.500 38.1	1.7/16 - 18 NEF

**10A**

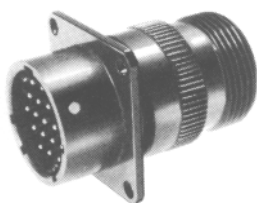

**62GB-10A**

4-Hole flange mounting with general duty back shell. No grommet supplied.

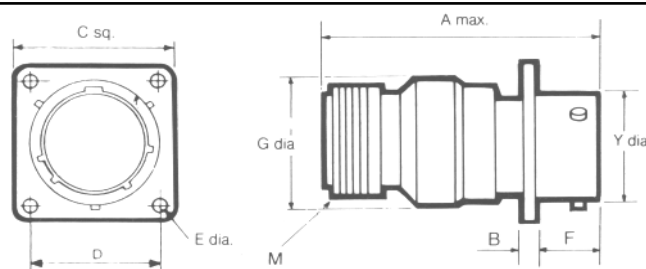

Shell Size	A max.	B ± 0.005 (± 0.13)	C Max. sq.	D TP sq.	E ± 0.010 (± 0.254)	F ± 0.005 (± 0.13)	G dia max.	Y dia. max.	M
08	1.624 41.25	0.062 1.58	0.817 20.75	0.594 15.09	0.120 3.05	0.445 11.3	0.561 14.25	0.473 12.02	1/2 - 28 UNEF
10	1.624 41.25	0.062 1.58	0.942 23.93	0.719 18.26	0.120 3.05	0.445 11.3	0.686 17.43	0.590 14.99	5/8 - 24 NEF
12	1.624 41.25	0.062 1.58	1.036 26.32	0.812 20.63	0.120 3.05	0.445 11.3	0.811 20.60	0.750 19.05	3/4 - 20 UNEF
14	1.624 41.25	0.062 1.58	1.130 28.70	0.906 23.10	0.120 3.05	0.445 11.3	0.936 23.78	0.875 22.23	7/8 - 20 UNEF
16	1.624 41.25	0.062 1.58	1.223 31.07	0.969 24.61	0.120 3.05	0.445 11.3	1.061 26.98	1.000 25.4	1 - 20 UNEF
18	1.624 41.25	0.062 1.58	1.317 33.45	1.062 26.58	0.120 3.05	0.445 11.3	1.186 30.12	1.125 28.58	1.3/16 - 18 NEF
20	1.687 42.85	0.080 2.03	1.442 36.63	1.156 29.36	0.120 3.05	0.555 14.10	1.311 33.30	1.250 31.75	1.3/16 - 18 NEF
22	1.687 42.85	0.080 2.03	1.567 39.80	1.250 31.75	0.120 3.05	0.555 14.10	1.436 36.47	1.375 34.93	1.7/16 - 18 NEF
24	1.730 43.94	0.080 2.03	1.692 42.98	1.375 34.93	0.147 3.73	0.590 14.99	1.561 39.65	1.500 38.1	1.7/16 - 18 NEF

# Box Mounting Receptacles

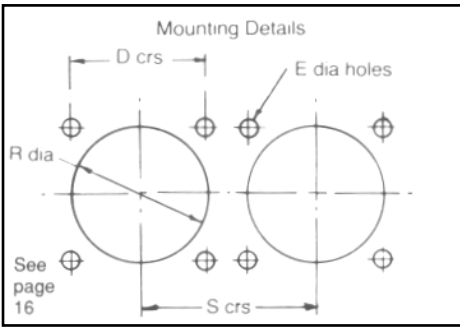

**10E**

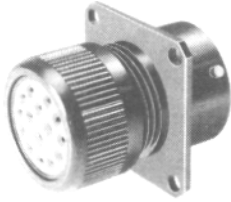

**62GB-10E**  
MIL-C-26482 MS3110E

4-hole flange mounting with grommet and grommet nut

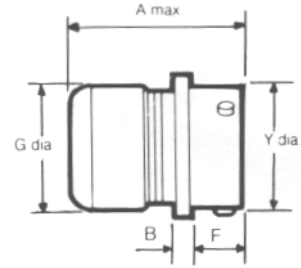
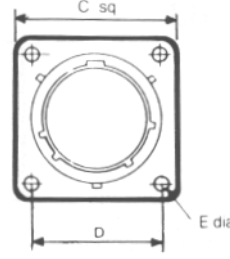

Shell Size	A max	B ± 0.005 (± 0.13)	C max sq.	D TP sq.	E ± 0.010 (± 0.254)	F ± 0.005 (± 0.13)	G dia max	V dia. max
08	1.281	0.062	0.817	0.594	0.120	0.445	0.561	0.473
	32.54	1.58	20.75	15.09	3.05	11.3	14.25	12.02
10	1.281	0.062	0.942	0.719	0.120	0.445	0.686	0.590
	32.54	1.58	23.93	18.26	3.05	11.3	17.43	14.99
12	1.281	0.062	1.036	0.812	0.120	0.445	0.811	0.750
	32.54	1.58	26.32	20.63	3.05	11.3	20.60	19.05
14	1.281	0.062	1.130	0.906	0.120	0.445	0.936	0.875
	32.54	1.58	28.70	23.10	3.05	11.3	23.78	22.23
16	1.281	0.062	1.223	0.969	0.120	0.445	1.061	1.000
	32.54	1.58	31.07	24.61	3.05	11.3	26.98	25.4
18	1.281	0.062	1.317	1.062	0.120	0.445	1.186	1.125
	32.54	1.58	33.45	26.58	3.05	11.3	30.12	28.58
20	1.383	0.080	1.442	1.156	0.120	0.555	1.311	1.250
	35.13	2.03	36.63	29.36	3.05	14.10	33.30	31.75
22	1.383	0.080	1.567	1.250	0.120	0.555	1.436	1.375
	35.13	2.03	39.80	31.75	3.05	14.10	36.47	34.93
24	1.383	0.080	1.692	1.375	0.147	0.590	1.561	1.500
	35.13	2.03	42.98	34.93	3.74	14.99	39.65	38.1

**10F**

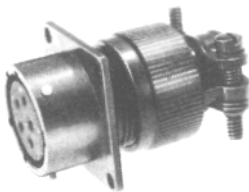

**62GB-10F**  
MIL-C-26482 MS31 10F

4-hole flange mounting with grommet and grommet nut fitted with integral strain relief clamp

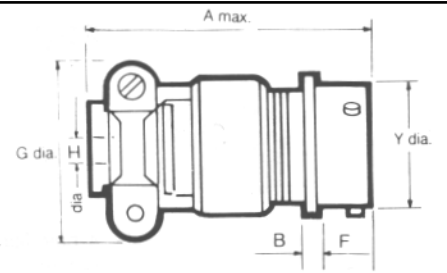
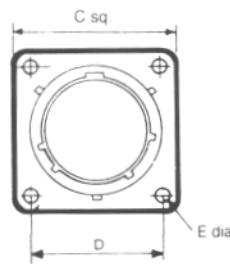

Shell Size	A max.	B ± 0.005 (± 0.13)	C max. sq.	D TP Sq.	E ± 0.010 (± 0.254)	F ± 0.005 (± 0.13)	G dia max.	H ± 0.005 (± 0.13)	Y dia. max.
08	1.762	0.062	0.817	0.594	0.120	0.445	0.828	0.156	0.473
	44.76	1.58	20.75	15.09	3.05	11.3	21.03	3.96	12.01
10	1.762	0.062	0.942	0.719	0.120	0.445	0.891	0.188	0.590
	44.76	1.58	23.92	18.26	3.05	11.3	22.63	4.78	14.99
12	1.762	0.062	1.036	0.812	0.120	0.445	1.016	0.312	0.750
	44.76	1.58	26.31	20.63	3.05	11.3	25.81	7.93	19.05
14	1.736	0.062	1.130	0.906	0.120	0.445	1.141	0.375	0.875
	44.10	1.58	28.70	23.10	3.05	11.3	28.98	9.58	22.23
16	1.876	0.062	1.223	0.969	0.120	0.445	1.203	0.500	1.000
	47.65	1.57	31.07	24.61	3.05	11.3	30.56	12.7	25.4
18	1.876	0.062	1.317	1.062	0.120	0.445	1.426	0.625	1.125
	47.65	1.58	33.45	26.58	3.05	11.3	36.22	15.87	28.58
20	2.118	0.080	1.442	1.156	0.120	0.555	1.426	0.625	1.250
	53.80	2.03	36.63	29.36	3.05	14.10	36.22	15.88	31.75
22	2.118	0.080	1.567	1.250	0.120	0.555	1.567	0.750	1.375
	53.80	2.03	39.80	31.75	3.05	14.10	39.80	19.05	34.93
24	2.250	0.080	1.692	1.375	0.147	0.590	1.735	0.800	1.500
	57.15	2.03	42.98	34.93	3.74	14.99	44.07	20.32	38.10



# Box Mounting Receptacles

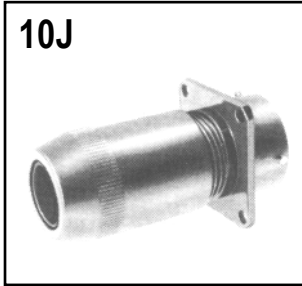
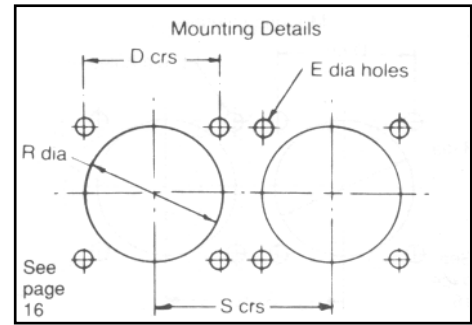

**10J**

**62GB-10J**

4-hole flange mounting with clamp for unscreened jacketed cable. No grommet supplied

Shell Size	A max	B ± 0.005 (± 0.13)	c max.sq	D TP sq	E ± 0.010 (± 0.254)	F ± 0.005 (± 0.13)	G dia. max	Y dia max	Z Cable Entry min closed	max free
08	1.846	0.062	0.817	0.594	0.120	0.445	0.561	0.473	0.168	0.230
	46.89	1.58	20.75	15.09	3.05	11.3	14.25	12.02	4.28	5.84
10	1.846	0.062	0.942	0.719	0.120	0.445	0.686	0.590	0.205	0.312
	46.89	1.58	23.93	18.26	3.05	11.3	17.43	14.99	5.21	7.93
12	1.947	0.062	1.036	0.812	0.120	0.445	0.811	0.750	0.338	0.442
	49.45	1.58	26.32	20.63	3.05	11.3	20.60	19.05	8.59	11.23
14	2.147	0.062	1.130	0.906	0.120	0.445	0.936	0.875	0.416	0.539
	54.54	1.58	28.70	23.10	3.05	11.3	23.78	22.23	10.57	13.69
16	2.347	0.062	1.223	0.969	0.120	0.445	1.061	1.000	0.550	0.616
	59.61	1.575	31.07	24.61	3.05	11.3	26.96	25.4	13.97	15.65
18	2.547	0.062	1.317	1.062	0.120	0.445	1.186	1.125	0.600	0.672
	64.70	1.575	33.45	26.58	3.05	11.3	30.12	28.58	15.24	17.07
20	2.831	0.080	1.442	1.156	0.120	0.555	1.311	1.250	0.635	0.747
	71.91	2.03	36.63	29.36	3.05	14.10	33.30	31.75	16.13	18.98
22	3.031	0.080	1.567	1.250	0.120	0.555	1.436	1.375	0.670	0.846
	76.99	2.03	39.80	31.75	3.05	14.10	36.47	34.93	17.02	21.49
24	3.074	0.080	1.692	1.375	0.147	0.590	1.561	1.500	0.740	0.894
	78.08	2.03	42.98	34.93	3.73	14.99	39.65	38.1	18.80	22.71

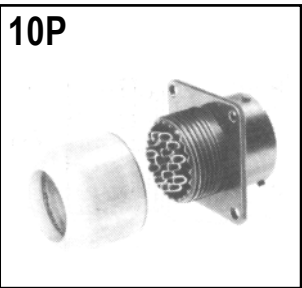

**10P**

**62GB-10P**

4-hole flange mounting for potting

Shell Size	A max	B ± 0.005 (± 0.13)	c max.sq.	D TP sq	E ± 0.010 (± 0.254)	F ± 0.005 (± 0.13)	G dia. max	Y dia. max	Z dia. min
08	1.453	0.062	0.817	0.594	0.120	0.445	0.572	0.473	0.260
	36.91	1.575	20.75	15.09	3.05	11.3	14.53	12.02	6.60
10	1.453	0.062	0.942	0.179	0.120	0.445	0.666	0.590	0.463
	36.91	1.58	23.93	18.26	3.05	11.3	16.92	14.99	11.76
12	1.453	0.062	1.036	0.812	0.120	0.445	0.822	0.750	0.577
	36.91	1.58	26.32	20.63	3.05	11.3	20.88	19.05	14.15
14	1.453	0.062	1.130	0.906	0.120	0.445	0.907	0.875	0.590
	36.91	1.58	28.70	23.10	3.05	11.3	23.04	22.23	14.99
16	1.453	0.062	1.223	0.969	0.120	0.445	1.040	1.000	0.713
	36.91	1.58	31.07	24.61	3.05	11.3	26.42	25.40	18.11
18	1.453	0.062	1.317	1.062	0.120	0.445	1.165	1.125	0.835
	36.91	1.58	33.45	26.58	3.05	11.3	29.60	28.58	22.21
20	1.672	0.080	1.442	1.156	0.120	0.555	1.285	1.250	1.015
	42.47	2.03	36.63	29.36	3.05	14.10	32.64	31.75	25.78
22	1.672	0.080	1.567	1.250	0.120	0.555	1.400	1.375	1.015
	42.47	2.03	39.80	31.75	3.05	14.10	35.56	34.93	25.78
24	1.734	0.080	0.692	1.375	0.147	0.590	1.540	1.500	1.265
	44.05	2.03	42.98	34.93	3.74	14.99	39.12	38.10	32.13

# Box Mounting Receptacles

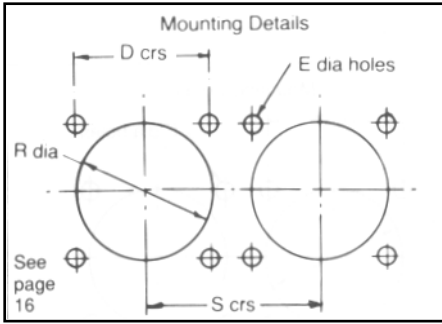

**62GB-12E**  
**BS9522 - F0017 - C2097**  
**MIL-C-26482 MS3112E**

Shell Size	A max	8 ± 0.005 (± 0.13)	C max sq.	D TP sq.	E ± 0.010 (± 0.254)	F ± 0.005 (± 0.13)	G dia. max.	L	V dia. max.
08	0.978	0.062	0.817	0.594	0.120	0.445	0.434	0.800	0.473
	24.84	1.58	20.75	15.09	3.05	11.3	11.02	20.32	12.02
10	0.978	0.062	0.942	0.719	0.120	0.445	0.558	0.800	0.590
	24.84	1.58	23.93	18.26	3.05	11.3	14.17	20.32	14.99
12	0.978	0.062	1.036	0.812	0.120	0.445	0.683	0.800	0.750
	24.84	1.58	26.32	20.63	3.05	11.3	17.35	20.32	19.05
14	0.978	0.062	1.130	0.906	0.120	0.445	0.808	0.800	0.875
	24.84	1.58	28.70	23.10	3.05	11.3	20.52	20.32	22.23
16	0.978	0.062	1.223	0.969	0.120	0.445	0.933	0.800	1.000
	24.84	1.58	31.07	24.61	3.05	11.3	23.70	20.32	25.4
18	0.978	0.062	1.317	1.062	0.120	0.445	1.057	0.800	1.125
	24.84	1.58	33.45	26.58	3.05	11.3	26.85	20.32	28.58
20	1.048	0.080	1.442	1.156	0.120	0.555	1.182	0.875	1.250
	26.62	2.03	36.63	29.36	3.05	14.10	30.02	22.23	31.75
22	1.048	0.080	1.567	1.250	0.120	0.555	1.307	0.875	1.375
	26.62	2.03	39.80	31.75	3.05	14.10	33.20	22.23	34.93
24	1.048	0.080	1.692	1.375	0.147	0.590	1.432	0.875	1.500
	26.62	2.03	42.98	34.93	3.74	14.99	36.37	22.23	38.1

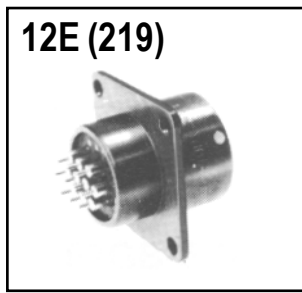

**62GB-12E (219)**  
**BS9522 - F0017 - C2262**

4-hole flange mounting with plain shell  
with film wire terminations

Shell Size	A max	B ± 0.005 (± 0.13)	C max sq.	D TP sq.	E dia 0.010	F ± 0.005 (± 0.13)	G dia. Max	J ± 0.020 (± 0.51)	K min max.	L max min	Y dia max.	Z
08	0.982	0.062	0.817	0.594	0.120	0.445	0.434	0.089	0.030 0.028	0.198 0.166	0.473 0.800	
	24.95	1.58	20.75	15.09	3.05	11.3	11.02	2.26 0.76	0.70 0.70	5.03 4.22	12.02 20.32	
10	0.982	0.062	0.942	0.719	0.120	0.445	0.558	0.089	0.030 0.028	0.198 0.166	0.590 0.800	
	24.95	1.58	23.93	18.26	3.05	11.3	14.17	2.26 0.76	0.70 0.70	5.03 4.22	14.99 20.32	
12	0.982	0.062	1.036	0.812	0.120	0.445	0.683	0.089	0.030 0.028	0.198 0.166	0.750 0.800	
	24.95	1.58	26.32	20.63	3.05	11.3	17.35	2.26 0.76	0.70 0.70	5.03 4.22	19.05 20.32	
14	0.982	0.062	1.130	0.906	0.120	0.445	0.808	0.089	0.030 0.028	0.198 0.166	0.875 0.800	
	24.95	1.58	28.70	23.10	3.05	11.3	20.52	2.26 0.76	0.70 0.70	5.03 4.22	22.23 20.32	
16	0.982	0.062	1.223	0.969	0.120	0.445	0.933	0.089	0.030 0.028	0.198 0.166	1.000 0.800	
	24.95	1.58	31.07	24.61	3.05	11.3	23.70	2.26 0.76	0.70 0.70	5.03 4.22	25.4 20.32	
18	0.982	0.062	1.317	1.062	0.120	0.445	1.057	0.089	0.030 0.028	0.198 0.166	1.125 0.800	
	24.95	1.58	33.45	26.58	3.05	11.3	26.85	2.26 0.76	0.70 0.70	5.03 4.22	28.58 20.32	
20	1.057	0.080	1.442	1.156	0.120	0.555	1.182	0.076	0.030 0.028	0.185 0.153	1.250 0.875	
	26.85	2.03	36.63	29.36	3.05	14.10	30.02	1.93 0.76	0.70 0.70	4.70 3.89	31.75 22.23	
22	1.057	0.080	1.567	1.250	0.120	0.555	1.307	0.076	0.030 0.028	0.185 0.153	1.375 0.875	
	26.85	2.03	39.80	31.75	3.05	14.10	33.20	1.93 0.76	0.70 0.70	4.70 3.89	34.93 22.23	
24	1.057	0.080	1.692	1.375	0.147	0.590	1.432	0.076	0.030 0.028	0.185 0.153	1.500 0.875	
	26.85	2.03	42.98	34.93	3.74	14.99	36.37	1.93 0.76	0.70 0.70	4.70 3.89	38.1 22.23	

# Box Mounting Receptacles Hermetic Seal

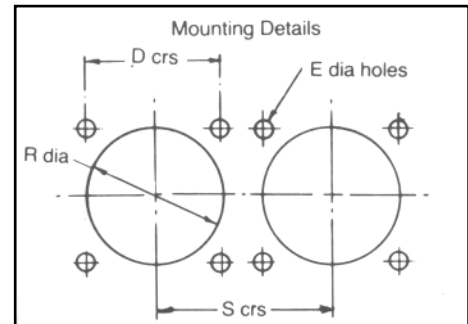

**62GB-12H**

4-hole square mounting with exposed solder buckets or flattened and pierced pins.

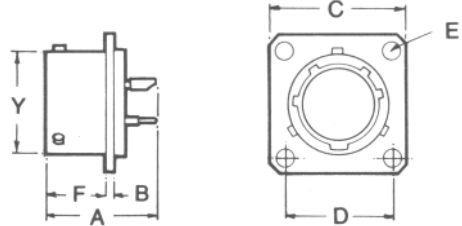



Shell Size	A max	B ± 0.005 (± 0.13)	C max sq.	D	E 0.008 (± 0.203) (±.051) .002	F ± 0.005 (± 0.13)	R ±0.005 (±0.13)	S	Y
08	0.828	0.062	0.812	0.594	0.120	0.443	0.568	1.250	0.473
	21.03	1.57	20.61	15.08	3.05	11.25	14.42	31.73	12.01
10	0.828	0.062	0.937	0.719	0.120	0.443	0.695	1.359	14.99
	21.03	1.57	23.79	18.29	3.05	11.25	17.53	34.52	14.99
12	0.828	0.062	1.031	0.812	0.120	0.443	0.864	1.531	0.750
	21.03	1.57	26.17	20.57	3.05	11.25	21.84	38.89	19.05
14	0.828	0.062	1.125	0.906	0.120	0.443	0.989	1.656	0.875
	21.03	1.57	28.57	23.11	3.05	11.25	25.15	42.06	22.23
16	0.828	0.062	1.218	0.969	0.120	0.443	1.113	1.781	1.000
	21.03	1.57	30.93	24.64	3.05	11.25	28.19	45.24	25.40
18	0.828	0.062	1.312	1.062	0.120	0.443	1.238	1.891	1.125
	21.03	1.57	33.32	26.92	3.05	11.25	31.49	48.03	28.58
20	0.890	0.093	1.437	1.156	0.120	0.561	1.363	2.031	1.250
	22.60	2.36	36.49	29.46	3.05	14.24	34.54	51.59	30.75
22	0.890	0.093	1.562	1.250	1.120	0.561	1.488	2.156	1.375
	22.60	2.36	39.67	31.75	3.05	14.24	37.85	54.76	34.93
24	0.890	0.093	1.687	1.375	0.147	0.593	1.615	2.277	1.500
	22.60	2.36	42.84	35.05	3.81	15.06	41.15	57.84	38.10

# Single Hole Fixing Receptacles

## Table of Styles

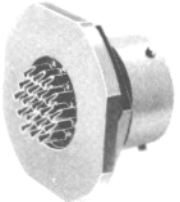
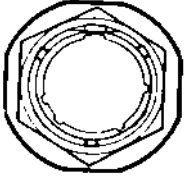
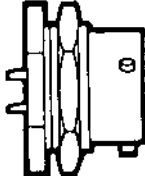
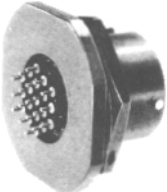
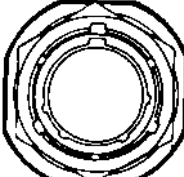
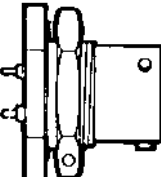
Page No.

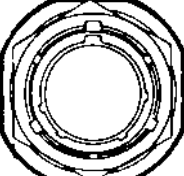
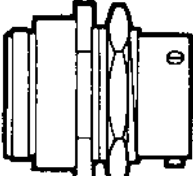
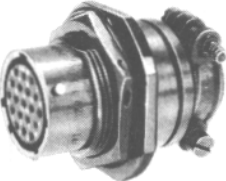
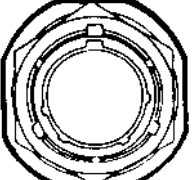
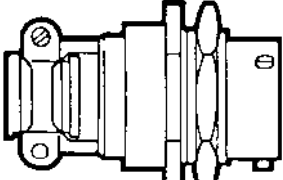
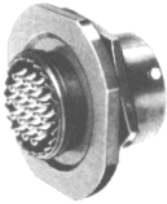
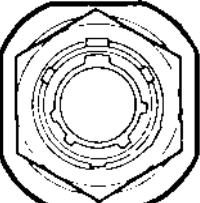
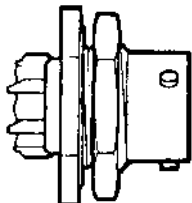
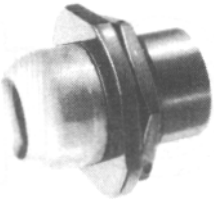
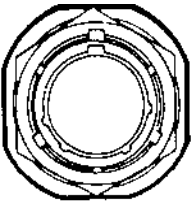
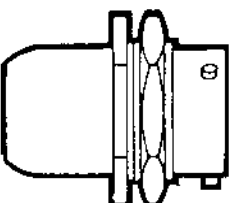
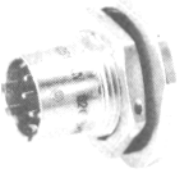
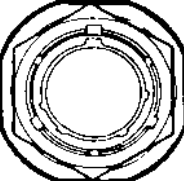
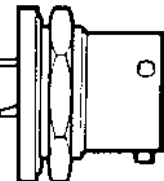
62GB-57A		 	20
62GB-57A (219)		 	20
62GB-14E		 	21
62GB-14F		 	21
62GB-57T		 	22
62GB-17P		 	22
62GB-17H Hermetic Seal		 	23

# Single Hole Fixing Receptacles

## Table of Styles

Page No.

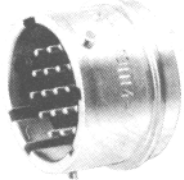
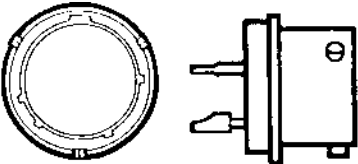
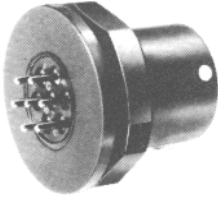
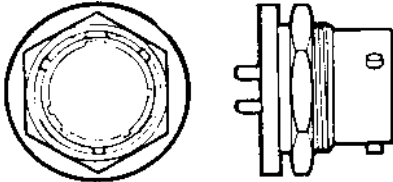
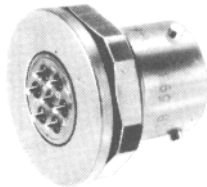
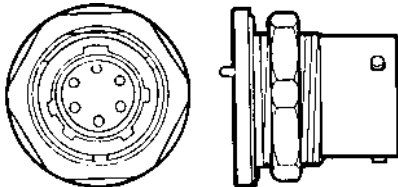
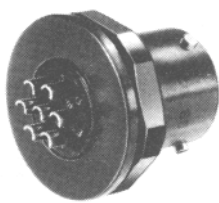
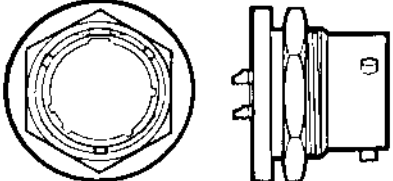
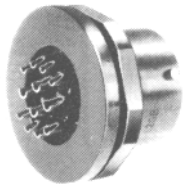
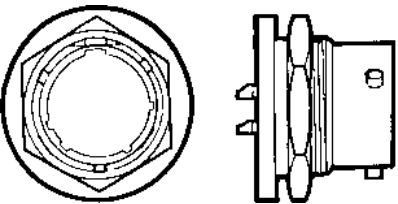
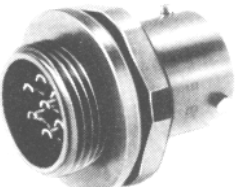
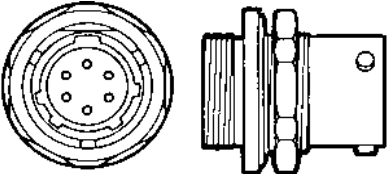
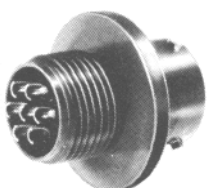
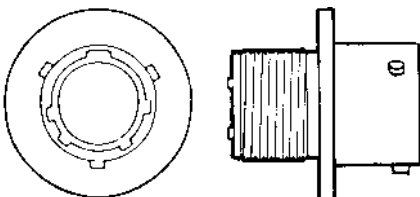
<p>62GB-1 3H Hermetic Seal</p>			<p>23</p>
<p>62GB-5005-10</p>			<p>24</p>
<p>62GB-5036-10</p>			<p>24</p>
<p>62GB-5016-10</p>			<p>25</p>
<p>62GB-5024</p>			<p>25</p>
<p>62GB-5052</p>			<p>26</p>
<p>62GB-5030</p>			<p>26</p>

# Single Hole Fixing Receptacles

## Table of Styles

Page No.

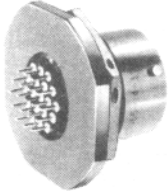
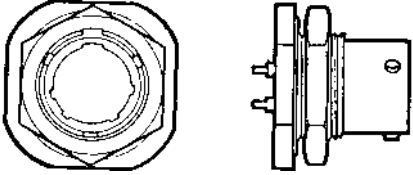
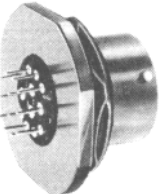
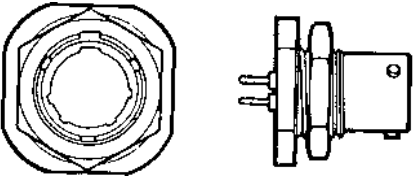
62GB-5065			27
62GB-5067			27

# Single Hole Fixing Receptacles

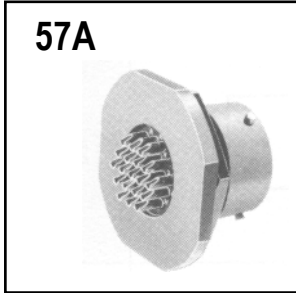
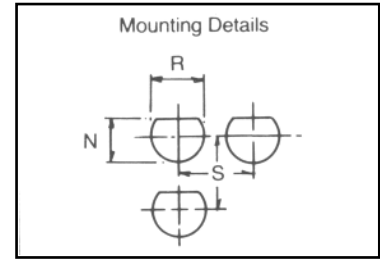

**62GB-57A**  
**BS9522 - F0017 - C2099**

Single hole mounting with plain shell for direct wiring to exposed solder buckets. Has panel 'O' ring seal.

Shell Size	A max	B ±0.005 (±0.13)	C sq.	F ±0.005 (±0.13)	K min	K max	L	M -0.005 (-0.13)	N ±0.005 (±0.13)	R ±0.005 (±0.13)	s min	Y	X Thread
08	0.978 24.84	0.117 2.97	0.942 23.93	0.706 17.93	0.062 1.58	0.125 3.18	0.750 19.05	0.527 13.3	0.540 13.72	0.572 14.53	1.250 31.75	0.473 12.03	9/16 - 24 NEF
10	0.978 24.84	0.117 2.97	1.067 27.10	0.706 17.93	0.062 1.58	0.125 3.18	0.875 22.23	0.652 16.56	0.665 16.89	0.697 17.70	1.359 34.52	0.590 14.99	11/16 - 24 NEF
12	0.978 24.84	0.117 2.97	1.255 31.88	0.706 17.93	0.062 1.58	0.125 3.18	1.062 26.98	0.815 20.70	0.828 21.03	0.885 22.48	1.531 38.89	0.750 19.05	7/8 - 20 UNEF
14	0.978 24.84	0.117 2.97	1.380 35.05	0.706 17.93	0.062 1.58	0.125 3.18	1.187 30.15	0.939 23.85	0.952 24.18	1.010 25.65	1.656 42.06	0.875 22.23	1 - 20 UNEF
16	0.978 24.84	0.117 2.97	1.505 38.23	0.706 17.93	0.062 1.58	0.125 3.18	1.312 33.32	1.063 27.00	1.076 27.33	1.135 28.83	1.781 45.24	1.000 25.40	1.1/8 - 18 NEF
18	0.978 24.84	0.117 2.97	1.630 41.40	0.706 17.93	0.062 1.58	0.125 3.18	1.437 36.50	1.188 30.18	1.201 30.50	1.260 32.00	1.891 48.03	1.125 28.58	1.1/4 - 18 NEF
20	1.048 26.62	0.148 3.76	1.817 46.15	0.894 22.71	0.062 1.58	0.250 6.35	1.562 38.68	1.313 33.35	1.326 33.68	1.385 35.18	2.031 51.59	1.250 31.75	1.3/8 - 18NEF
22	1.048 26.62	0.148 3.76	1.942 49.33	0.894 22.71	0.062 1.58	0.250 6.35	1.687 42.85	1.438 36.53	1.451 36.86	1.510 38.35	2.156 54.76	1.375 34.93	1.1/2 - 18 NEF
24	1.048 26.62	0.148 3.76	2.067 52.50	0.927 23.55	0.062 1.575	0.250 6.35	1.812 46.05	1.563 39.70	1.576 40.03	1.635 41.45	2.277 57.84	1.500 38.10	1.5/8 - 18 NEF



**62GB-57A (219)**  
**BS9522 - F0017- C2261**

Single hole mounting with plain shell and film wire terminations

Shell Size	A m	B ±0.005 (±0.13)	C sq. max.	max	D min	F ±0.005 (±0.13)	max	H min	min	K max	L	M -0.005 (-0.13)	N ±0.005 (±0.13)	R ±0.005 (±0.13)	S min	Y	X Thread
08	0.976 24.79	0.117 2.97	0.942 23.93	0.030 0.76	0.028 0.71	0.706 17.93	0.173 4.40	0.133 3.38	0.062 1.58	0.125 3.18	0.750 19.05	0.527 13.3	0.540 13.72	0.572 14.53	1.250 31.75	0.473 12.03	9/16 - 24 NEF
10	0.976 24.79	0.117 2.97	1.067 27.10	0.030 0.76	0.028 0.71	0.706 17.93	0.173 4.40	0.133 3.38	0.062 1.58	0.125 3.18	0.875 22.23	0.652 16.56	0.665 16.89	0.697 17.70	1.359 34.52	0.590 14.99	11/16 - 24 NEF
12	0.976 24.79	0.117 2.97	1.255 31.88	0.030 0.76	0.028 0.71	0.706 17.93	0.173 4.40	0.133 3.38	0.062 1.58	0.125 3.18	1.062 26.98	0.815 20.70	0.828 21.03	0.885 22.48	1.531 38.89	0.750 19.05	7/8 - 20 UNEF
14	0.976 24.79	0.117 2.97	1.380 35.05	0.030 0.76	0.028 0.71	0.706 17.93	0.173 4.40	0.133 3.38	0.062 1.58	0.125 3.18	1.187 30.15	0.939 23.85	0.952 24.18	1.010 25.65	1.656 42.06	0.875 22.23	1 - 20 UNEF
16	0.976 24.79	0.117 2.97	1.505 38.23	0.030 0.76	0.028 0.71	0.706 17.93	0.173 4.40	0.133 3.38	0.062 1.58	0.125 3.18	1.312 33.32	1.063 27.00	1.076 27.33	1.135 28.83	1.781 45.24	1.000 25.40	1.1/8 - 18 NEF
18	0.976 24.79	0.117 2.97	1.630 41.40	0.030 0.76	0.028 0.71	0.706 17.93	0.173 4.40	0.133 3.38	0.062 1.58	0.125 3.18	1.437 36.50	1.188 30.18	1.201 30.50	1.260 32.00	1.891 48.03	1.125 28.58	1.1/4 - 18 NEF
20	1.195 30.35	0.148 3.76	1.817 46.15	0.030 0.76	0.028 0.71	0.894 22.71	0.173 4.40	0.133 3.38	0.062 1.58	0.250 6.35	1.562 38.68	1.313 33.35	1.326 35.18	1.385 35.18	2.031 51.59	1.250 31.75	1.3/8 - 18 NEF
22	1.195 30.35	0.148 3.76	1.942 49.33	0.030 0.76	0.028 0.71	0.894 22.71	0.173 4.40	0.133 3.38	0.062 1.58	0.250 6.35	1.687 42.85	1.438 36.53	1.451 36.86	1.510 38.35	2.156 54.76	1.375 34.93	1.1/2 - 18NEF
24	1.228 30.35	0.148 3.76	2.067 52.50	0.030 0.76	0.028 0.71	0.927 23.55	0.173 4.40	0.133 3.38	0.062 1.58	0.250 6.35	1.812 46.05	1.563 39.70	1.576 40.03	1.635 41.45	2.277 57.84	1.500 38.10	1.5/8 - 18 NEF

# Single Hole Fixing Receptacles

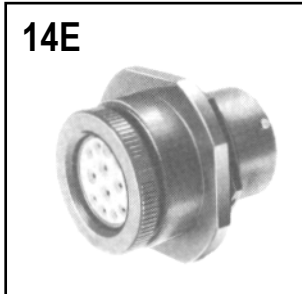
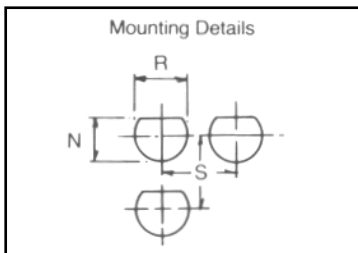

**14E**

**62GB-14E**  
**MIL-C-26482 MS3114E**  
**BS9522 - F0017**  
**- C2098**

Single hole mounting with grommet and grommet nut.  
 Has panel 'O' ring seal

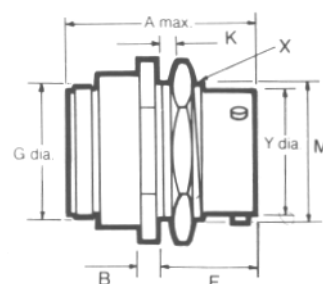
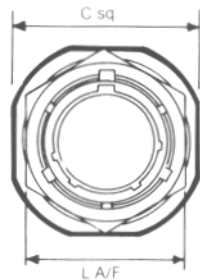

Shell Size	A max	B ±0.005 (±0.13)	C max sq.	F ±0.005 (±0.13)	G Dia Max	min	K max	L	M -0.005 (-0.13)	N ±0.005 (±0.13)	R ±0.005 (±0.13)	S	Y	X Thread
08	1.344	0.117	0.942	0.706	0.713	0.062	0.125	0.750	0.527	0.540	0.572	1.250	0.473	9/16-24NEF
	34.14	2.97	23.93	17.93	18.11	1.58	3.18	19.05	13.3	13.72	14.53	31.75	12.03	
10	1.344	0.117	1.067	0.706	0.838	0.062	0.125	0.875	0.652	0.665	0.697	1.359	0.590	11/16-24 NEF
	34.14	2.97	27.10	17.93	21.29	1.58	3.18	22.23	16.56	16.89	17.70	34.52	14.99	
12	1.344	0.117	1.255	0.706	0.963	0.062	0.125	1.062	0.815	0.828	0.885	1.531	0.750	7/8-20 UNEF
	34.14	2.97	31.88	17.93	24.46	1.58	3.18	26.98	20.70	21.03	22.48	38.89	19.05	
14	1.344	0.117	1.380	0.706	1.088	0.062	0.125	1.187	0.939	0.952	1.010	1.656	0.875	1-20 UNEF
	34.14	2.97	35.05	17.93	27.63	1.58	3.18	30.15	23.85	24.18	25.65	42.06	22.23	
16	1.344	0.117	1.505	0.706	1.213	0.062	0.125	1.312	1.063	1.076	1.135	1.781	1.000	1.1/8-18NEF
	34.14	2.97	38.23	17.93	30.81	1.58	3.18	33.32	27.00	27.33	28.83	45.24	25.40	
18	1.344	0.117	1.630	0.706	1.338	0.062	0.125	1.437	1.188	1.201	1.260	1.891	1.125	1.1/4-18 NEF
	34.14	2.97	41.40	17.93	33.98	1.58	3.18	36.50	30.18	30.50	32.00	48.03	28.58	
20	1.576	0.148	1.817	0.894	1.463	0.062	0.250	1.562	1.313	1.326	1.385	2.031	1.250	1.3/8-18 NEF
	40.03	3.76	46.15	22.71	37.16	1.58	6.35	38.68	33.35	33.68	35.18	51.59	31.75	
22	1.576	0.148	1.942	0.894	1.588	0.062	0.250	1.687	1.438	1.451	1.510	2.156	1.375	1.1/2-18 NEF
	40.03	3.76	49.33	22.71	40.33	1.58	6.35	42.85	36.53	36.86	38.35	54.76	34.93	
24	1.609	0.148	2.067	0.927	1.713	0.062	0.250	1.812	1.563	1.576	1.635	2.277	1.500	1.5/8-18 NEF
	40.87	3.76	52.50	23.55	43.51	1.58	6.35	46.05	39.70	40.03	41.45	57.84	38.10	



**14F**

**62GB-14F**  
**MIL-C-26482 MS3114F**

Single hole mounting with grommet and grommet nut fitted with integral strain relief clamp.  
 Has panel 'O' ring seal

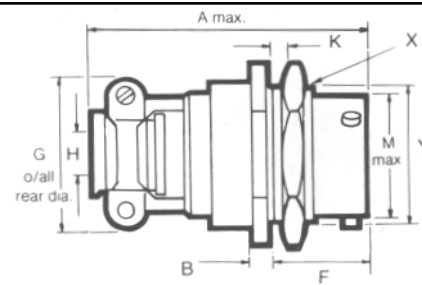
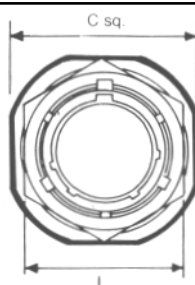

Shell Size	A max	B ±0.005 (±0.13)	C max sq.	F ±0.005 (±0.13)	G dia. max.	H 0.005 (±0.13)	min	K max	L	M -0.005 (-0.13)	N ±0.005 (±0.13)	R ±0.005 (±0.13)	S	Y	X Thread
08	1.762	0.117	0.942	0.706	0.828	0.156	0.062	0.125	0.750	0.527	0.540	0.572	1.250	0.473	9/16-24 NEF
	44.75	2.97	23.93	17.93	21.03	3.96	1.58	3.18	19.05	13.3	13.72	14.53	31.75	12.03	
10	1.762	0.117	1.067	0.706	0.891	0.188	0.062	0.125	0.875	0.652	0.665	0.697	1.359	0.590	11/16-124 NEF
	44.75	2.97	27.10	17.93	22.63	4.78	1.58	3.18	22.23	16.56	16.89	17.70	34.52	14.99	
12	1.762	0.117	1.255	0.706	1.016	0.312	0.062	0.125	1.062	0.815	0.828	0.885	1.531	0.750	7/8-20 UNEF
	44.75	2.97	31.88	17.93	25.81	7.93	1.58	3.18	26.98	20.70	21.03	22.48	38.89	19.05	
14	1.736	0.117	1.380	0.706	1.147	0.375	0.062	0.125	1.187	0.939	0.952	1.010	1.656	0.875	1-20 NEF
	44.10	2.97	35.05	17.93	28.97	9.53	1.58	3.18	30.15	23.85	24.18	25.65	42.06	22.23	
16	1.876	0.117	1.505	0.706	1.203	0.500	0.062	0.125	1.312	1.063	1.076	1.135	1.781	1.000	1.1/8-18 NEF
	47.65	2.97	38.23	17.93	30.56	12.7	1.58	3.18	33.32	27.00	27.33	28.83	45.24	25.40	
18	1.876	0.117	1.630	0.706	1.426	0.625	0.062	0.125	1.437	1.188	1.201	1.260	1.891	1.125	1.1/4-18 NEF
	47.65	2.97	41.40	17.93	36.22	15.88	1.58	3.18	36.50	30.18	30.50	32.00	48.03	28.58	
20	2.118	0.148	1.817	0.894	1.426	0.625	0.062	0.250	1.562	1.313	1.326	1.385	2.031	1.250	1.3/8-18 NEF
	53.8	3.76	46.15	22.71	36.22	15.88	1.58	6.35	38.68	33.35	33.68	35.18	51.59	31.75	
22	2.118	0.148	1.942	0.894	1.567	0.750	0.062	0.250	1.687	1.438	1.451	1.510	2.756	1.375	1.1/2-18 NEE
	53.8	3.76	49.33	22.71	39.80	19.05	1.58	6.35	42.85	36.53	36.86	38.35	54.76	34.93	
24	2.250	0.148	2.067	0.927	1.735	0.800	0.062	0.250	1.812	1.563	1.576	1.635	2.277	1.500	1.5/8-18 NEF
	57.15	3.76	52.50	23.55	44.07	20.32	1.58	6.35	46.05	39.70	40.03	41.45	57.84	38.10	



# Single Hole Fixing Receptacles

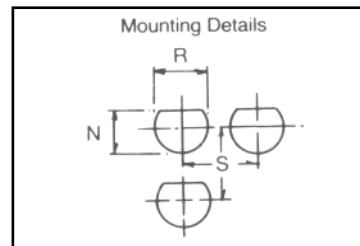

57T

**62G B-57T**  
**BS9522 - F0017 - C2100**

Single hole mounting with threaded shell to accept accessories

Shell Size	A max	B ± 0.005 (±0.13)	c max. sq.	F ± 0.005 (±0.13)	G dia. max.	K min	K max	L	M -0.005 (-0.13)	N	Y	X Thread
08	0.978	0.117	0.942	0.595	0.426	0.062	0.125	0.750	0.527	7/16 - UNEF	0.473	9/16 - 24 NEF
	24.84	2.97	23.93	15.12	10.82	1.58	3.18	19.05	13.3		12.03	
10	0.978	0.117	1.067	0.595	0.552	0.062	0.125	0.875	0.652	9/16 - UNEF	0.590	11/16 - 24 NEF
	24.84	2.97	27.10	15.12	14.02	1.58	3.18	22.23	16.56		14.99	
12	0.978	0.117	1.255	0.595	0.677	0.062	0.125	1.062	0.815	11/16 - UNEF	0.750	7/8 - 20 UNEF
	24.84	2.97	31.88	15.12	17.20	1.58	3.18	26.98	20.70		19.05	
14	0.978	0.117	1.380	0.595	0.802	0.062	0.125	1.187	0.939	13/16 - UNEF	0.875	1 - 20 UNEF
	24.84	2.97	35.05	15.12	20.37	1.58	3.18	30.15	23.85		22.23	
16	0.978	0.117	1.505	0.595	0.927	0.062	0.125	1.312	1.063	15/16 - UNEF	1.000	1.1/18 - 18 NEF
	24.84	2.97	38.23	15.12	23.55	1.58	3.18	33.32	27.00		25.40	
18	0.978	0.117	1.630	0.595	1.052	0.062	0.125	1.437	1.188	1.1/16 - UNEF	1.125	1.1/4 - 18 NEF
	24.84	2.98	41.40	15.12	26.72	1.58	3.18	36.50	30.18		28.58	
20	1.048	0.148	1.817	0.720	1.167	0.062	0.250	1.562	1.313	1.3/16 - UNEF	1.250	1.3/8 - 18 NEF
	26.62	3.76	46.15	18.29	29.65	1.58	6.35	38.68	33.35		31.75	
22	1.048	0.148	1.942	0.720	1.292	0.062	0.250	1.687	1.438	1.5/16 - UNEF	1.375	1.1/2 - 18 NEF
	26.62	3.76	49.33	18.29	32.82	1.58	6.35	42.85	36.53		34.93	
24	1.048	0.148	2.067	0.753	1.416	0.062	0.250	1.812	1.563	1.7/16 - UNEF	1.50	1.5/8 - 18 NEF
	26.62	3.76	52.50	19.13	35.97	1.58	6.35	46.05	39.70		38.10	

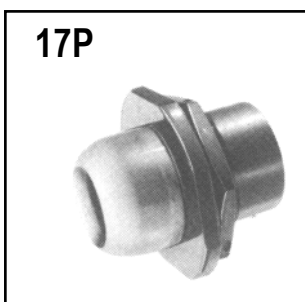

17P

**62GB-17P**  
**MIL-C-26482 MS3114P**

Single hole mounting for potting. Supplied complete with potting mould locating ring and panel 'O' ring seal

Shell Size	A max.	B ±0.005 (±0.13)	C max. sq.	F ± 0.005 (±0.13)	G	K min	K max.	L	M -0.005 (-0.13)	N ±0.005 (±0.13)	R ±0.005 (±0.13)	Y	Z	X Thread	
08	1.391	0.117	0.942	0.706	0.572	0.062	0.125	0.750	0.527	0.540	0.572	1.250	0.473	0.260	9/16 - 24 NEF
	35.33	2.97	23.93	17.93	14.53	1.58	3.175	19.05	13.3	13.72	14.53	31.75	12.03	6.60	
10	1.391	0.117	1.067	0.706	0.666	0.062	0.125	0.875	0.652	0.665	0.697	1.359	0.590	0.463	11/16 - 24 NEF
	35.33	2.97	27.10	17.93	16.92	1.58	3.18	22.23	16.56	16.89	17.70	34.52	14.99	11.76	
12	1.391	0.117	1.255	0.706	0.822	0.062	0.125	1.062	0.815	0.828	0.885	1.531	0.750	0.557	7/8 - 20 UNEF
	35.33	2.97	31.88	17.93	20.88	1.58	3.18	26.98	20.70	21.03	22.48	38.89	19.05	14.15	
14	1.391	0.117	1.380	0.706	0.907	0.062	0.125	1.187	0.939	0.952	1.010	1.656	0.875	0.590	1 - 20 UNEF
	35.33	2.97	35.05	17.93	23.06	1.58	3.18	30.15	23.85	24.18	25.65	42.06	22.23	14.99	
16	1.391	0.117	1.505	0.706	1.040	0.062	0.125	1.312	1.063	1.076	1.135	1.781	1.000	0.713	1.1/18 - 18 NEF
	35.33	2.97	38.23	17.93	26.42	1.58	3.18	33.32	27.00	27.33	28.83	45.24	25.40	18.11	
18	1.391	0.117	1.630	0.706	1.165	0.062	0.125	1.437	1.188	1.201	1.260	1.891	1.125	0.835	1.1/4 - 18 NEF
	35.33	2.97	41.40	17.93	29.59	1.58	3.175	36.50	30.18	30.50	32.00	48.03	28.58	21.21	
20	1.641	0.148	1.817	0.894	1.285	0.062	0.250	1.562	1.313	1.326	1.385	2.031	1.250	1.015	1.3/8 - 18 NEF
	41.68	3.76	46.15	22.71	32.64	1.58	6.35	38.68	33.35	33.68	35.18	51.59	31.75	25.78	
22	1.641	0.148	1.942	0.894	1.400	0.062	0.250	1.687	1.438	1.451	1.510	2.156	1.375	1.015	1.1/2 - 18 NEF
	41.68	3.76	49.33	22.71	35.56	1.58	6.35	42.85	36.53	36.86	38.35	54.76	34.93	25.78	
24	1.674	0.148	2.067	0.927	1.540	0.062	0.250	1.812	1.563	1.576	1.635	2.277	1.500	1.265	1.5/8 - 18 NEF
	42.52	3.76	52.50	23.55	39.12	1.58	6.35	46.05	39.70	40.03	41.45	57.84	38.10	32.13	

# Single Hole Fixing Receptacles

## Hermetic Seal

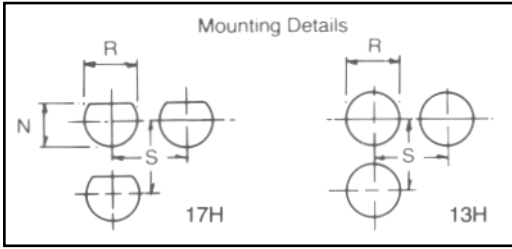

**17H**



**62GB-17H**  
**MIL-C-26482 MS3114H**

Single hole mounting with pin contacts in one piece glass-to-metal seal. Exposed solder buckets or flattened and pierced pins.  
Has panel 'O' ring seal

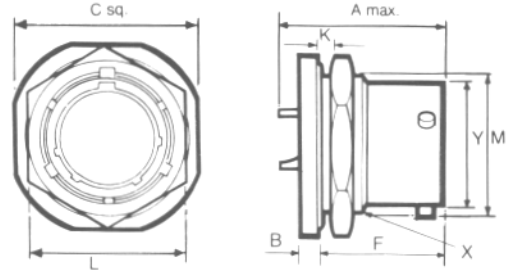

Shell Size	A max.	B ±0.005 (±0.13)	C max. sq	F ±0.005 (±0.13)	min	K max	L	M -0.005 (-0.13)	N ±0.005 (±0.13)	R ±0.005 (±0.13)	S	Y	X Thread
08	0.828	0.094	0.942	0.706	0.062	0.125	0.750	0.527	0.540	0.572	1.250	0.473	9/16 - 24 NEF
	21.03	2.39	23.93	17.93	1.57	3.18	19.05	13.39	13.72	14.53	31.75	12.01	
10	0.828	0.094	1.067	0.706	0.062	0.125	0.875	0.652	0.665	0.697	1.359	0.590	11/16 - 24 NEF
	21.03	2.39	27.10	17.93	1.57	3.18	22.23	16.56	16.89	17.70	34.52	14.99	
12	0.828	0.094	1.255	0.706	0.062	0.125	1.062	0.815	0.828	0.885	1.531	0.750	7/8 - 20 UNEF
	21.03	2.39	31.88	17.93	1.57	3.18	26.97	20.70	21.03	22.48	38.89	19.05	
14	0.828	0.094	1.380	0.706	0.062	0.125	1.187	0.939	0.952	1.010	1.656	0.875	1 - 20 UNEF
	21.03	2.39	35.05	17.93	1.57	3.18	30.15	23.85	24.18	25.65	42.06	22.23	
16	0.828	0.094	1.505	0.706	0.062	0.125	1.312	1.063	1.076	1.135	1.781	1.000	1.1/8 - 18 NEF
	21.03	2.39	38.23	17.93	1.57	3.18	33.32	27.00	27.33	28.53	45.24	25.40	
18	0.828	0.094	1.630	0.706	0.062	0.125	1.437	1.188	1.201	1.260	1.891	1.125	1.1/4 - 18 NEF
	21.03	2.39	41.40	17.93	1.57	3.18	36.50	30.18	30.51	32.00	48.03	28.58	
20	0.828	0.125	1.817	0.894	0.062	0.250	1.562	1.313	1.326	1.385	2.031	1.250	1.3/8 - 18 NEF
	21.03	3.18	46.15	22.71	1.57	6.35	39.67	33.35	33.68	35.18	51.59	30.75	
22	0.890	0.125	1.942	0.894	0.062	0.250	1.687	1.438	1.451	1.510	2.156	1.375	1.1/2 - 18 NEF
	22.61	3.18	49.33	22.71	1.57	6.35	42.85	36.53	36.86	38.35	54.76	34.93	
24	0.890	0.125	2.067	0.927	0.062	0.250	1.812	1.563	1.576	1.635	2.277	1.500	1.5/8 - 18 NEF
	22.61	3.18	52.50	23.55	1.57	6.35	46.02	39.70	40.03	41.53	57.84	38.10	

**13H**

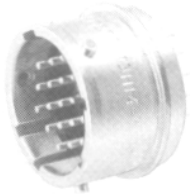

**62GB-1 3H**  
**MIL-C-26482 MS3113H**

Solder mounting with plain shell and exposed solder buckets or flattened and pierced pins

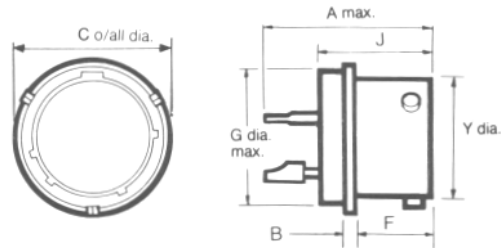

Shell Size	A max	B ±0.005 (± 0.13)	c max	F ±0.005 (± 0.13)	G max	J max	R ±0.005 (± 0.13)	S min	Y dia. max
08	0.828	0.036	0.630	0.426	0.562	0.592	0.578	1.250	0.473
	21.03	0.91	16.00	10.82	14.27	15.04	14.68	31.75	12.01
10	0.828	0.036	0.755	0.426	0.672	0.592	0.687	1.359	0.590
	21.03	0.91	19.18	10.82	17.07	15.04	17.45	34.52	14.99
12	0.828	0.036	0.849	0.426	0.781	0.592	0.797	1.531	0.750
	21.03	0.91	21.56	10.82	19.84	15.04	20.24	38.89	19.05
14	0.828	0.036	0.974	0.426	0.906	0.592	0.922	1.656	0.875
	21.03	0.91	24.74	10.82	23.01	15.04	23.42	42.06	22.23
16	0.828	0.036	1.099	0.426	1.031	0.592	1.047	1.781	1.000
	21.03	0.91	27.91	10.82	26.19	15.04	26.59	45.24	25.40
18	0.828	0.036	1.223	0.426	1.156	0.592	1.172	1.891	1.125
	21.03	0.91	31.06	10.82	29.36	15.04	29.77	48.03	28.58
20	0.890	0.036	1.317	0.488	1.250	0.658	1.266	2.031	1.250
	22.61	0.91	33.45	12.40	31.75	16.70	32.16	51.59	30.75
22	0.890	0.036	1.443	0.488	1.375	0.686	1.390	2.156	1.375
	22.61	0.91	36.65	12.40	34.93	17.42	35.31	54.76	34.93
24	0.890	0.036	1.567	0.521	1.500	0.719	1.516	2.277	1.500
	22.61	0.91	39.80	13.23	38.10	18.26	38.51	57.84	38.10

# Single Hole Fixing Receptacles

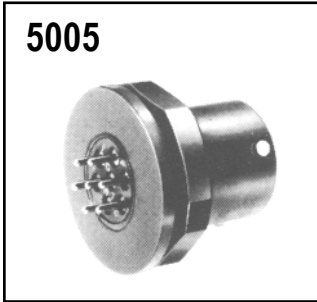
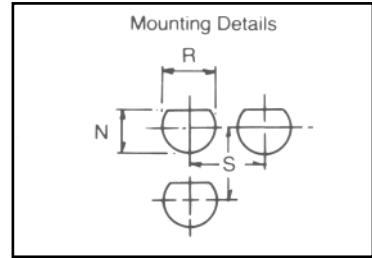

**5005**

**62GB-5005-10**  
(RSRE SD/C 235025/X)

Single hole mounting plain shell with PC pin terminated contacts. Reduced diameter flange with panel 'O' seal

Size 10 only

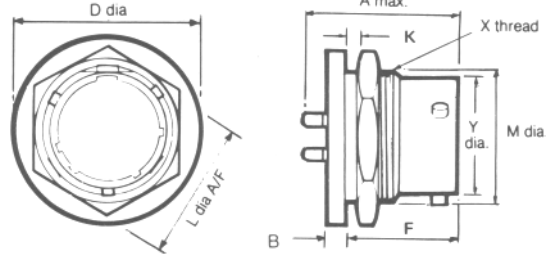

	A max	B +0.001 -0.002 (+0.03) (-0.03)	D dia. max	F +0.002 -0.003 (+0.05) (-0.08)	min	K max	M -0.005 (-0.13)	N ±0.003 (±0.08)	R +0.005 (+0.13)	S	Y dia. max.	X Thread	L dia
10	0.877 22.28	0.065 1.65	0.880 22.35	0.681 17.29	0.062 1.58	0.125 3.18	0.655 16.63	0.659 16.47	0.690 17.52	1.017 25.83	0.590 14.99	11/16 – 24 NEF	0.820 20.83

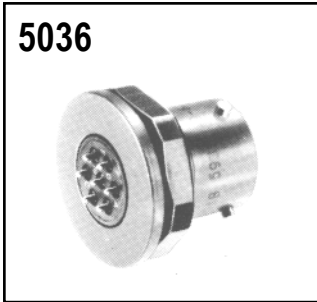

**5036**

**62GB-5036-10**  
(RSRE SD/C235025/X)

Single hole mounting with circular flange and P.C. terminations

Size 10 only

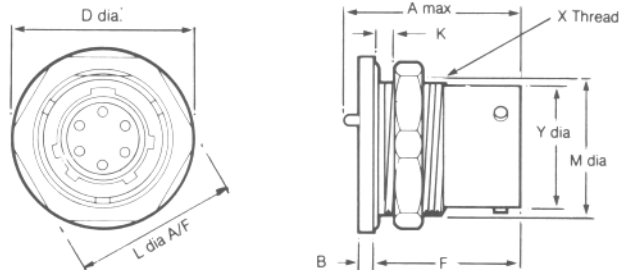

Shell Size	A max	B +0.001 -0.002 (+0.03) (-0.05)	D dia. max	F +0.002 -0.003 (+0.05) (-0.08)	Y dia. max.	min	K max	M -0.005 (-0.13)	N ±0.003 (±0.08)	R +0.005 (+0.13)	S	X Thread	L dia
10	0.829 21.06	0.066 1.67	0.880 22.35	0.679 17.25	0.590 14.99	0.062 1.57	0.125 3.18	0.655 16.63	0.659 16.47	0.690 17.52	1.017 25.83	11/16 – 24 NEF	0.820 20.83

# Single Hole Fixing Receptacles

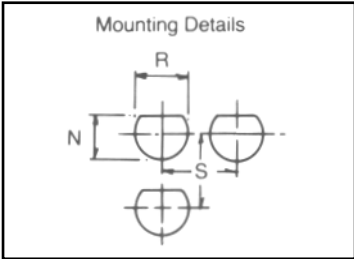

**5016**

**62GB-5016-10**  
(RSRE SD/C 235025/X)

Single hole mounting plain shell for direct wiring to exposed solder buckets. Reduced diameter flange with panel 'O' ring seal

Solder bucket: Size 10 only

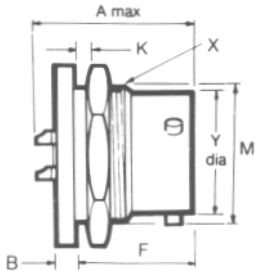
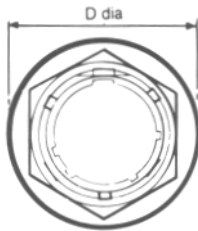

Shell Size	A max	B +0.002 -0.001 (+0.05) (-0.03)	D dia. max	F + 0.003 - 0.002 (+ 0.08) (- 0.05)	K min max		M - 0.010 (- 0.25)	N ± 0.005 (± 0.13)	R + 0.005 (+ 0.13)	S	Y dia. max.	X Thread
10	0.902 22.91	0.064 1.62	0.880 22.35	0.678 17.21	0.062 1.58	0.125 3.18	0.655 16.63	0.665 16.89	0.697 17.70	1.359 34.52	0.590 14.99	11/16 - 24 NEF



**5024**

**62GB-5024**  
(RSRE SD/C 35077/X)

Single hole mounting plain shell for direct wiring to exposed solder buckets. Reduced diameter flange with panel 'O' ring seal

Solder buckets: Size 8, 12 and 14 only

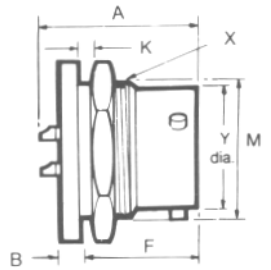
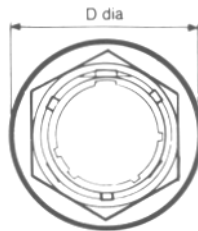

Shell Size	A max	B ± 0.005 (± 0.13)	D dia. max	F ± 0.005 (± 0.13)	K min max		M - 0.005 (- 0.13)	N ± 0.005 (± 0.13)	R ± 0.005 (± 0.13)	S min	Y dia. max	X Thread
08	0.978 24.84	0.117 2.97	0.830 21.08	0.706 17.93	0.062 1.58	0.125 3.18	0.527 13.3	0.540 13.72	0.572 14.53	1.250 31.75	0.473 12.03	9/16 - 24 NEF
12	0.978 24.84	0.117 2.97	1.130 28.70	0.706 17.93	0.062 1.58	0.125 3.18	0.815 20.70	0.828 21.03	0.885 22.48	1.531 38.89	0.750 19.05	7/8 - 20 UNEF
14	0.978 24.84	0.117 2.97	1.260 32.00	0.706 17.93	0.062 1.58	0.125 3.18	0.939 23.85	0.952 24.18	1.010 25.65	1.656 42.06	0.875 22.23	1 - 20 UNEF

# Single Hole Fixing Receptacles

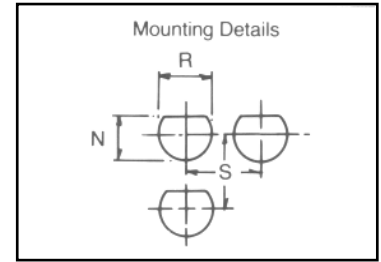

## 62GB-5052-10

Single hole fixing with circular flange and back end thread - solder termination

Size 10 only

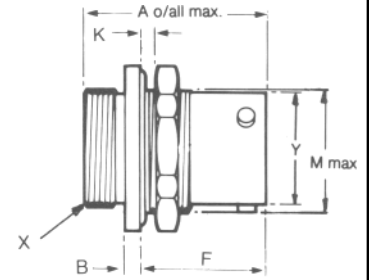
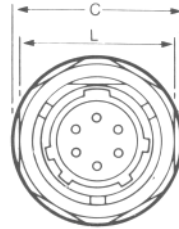

Shell Size	A max	B (± 0.05) (± 0.03)	C max. sq.	F + 0.003 - 0.002 (+ 0.08) (- 0.05)	K min max	L	M - 0.005 (- 0.13)	N ± 0.005 (± 0.13)	R ± 0.005 (± 0.13)	S ± 0.005 (± 0.13)	X Thread
10	0.947 24.06	0.062 1.58	0.880 22.35	0.677 17.19	0.062 1.58 0.125 3.18	0.820 20.83	0.650 16.51	5/8 - 24 UNEF	0.697 17.70	1.359 34.52	11/16 - 24 NEF



## 62G B-5030

Bulkhead mounting receptacle with solder terminations

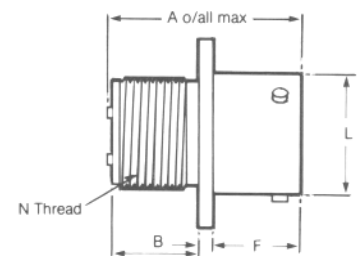
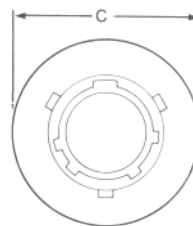

Shell Size	A max	B ± 0.005 (± 0.13)	C ± 0.010 (± 0.25)	F ± 0.005 (± 0.13)	L	N Thread
08	0.978 24.85	0.094 2.39	0.812 20.63	0.415 10.54	0.563 14.30	7/16 - 28 UNEF
10	0.978 24.85	0.094 2.39	0.937 23.80	0.415 10.54	0.680 17.28	9/16 - 24 NEF
12	0.978 24.85	0.094 2.39	1.031 26.19	0.415 10.54	0.859 21.82	11 / 16 - 24 NEF
14	0.978 24.85	0.094 2.39	1.125 28.58	0.415 10.54	0.984 25.00	13/16 - 20 UNEF
16	0.978 24.85	0.094 2.39	1.218 30.94	0.415 10.54	1.108 28.15	15/16 - 20 UNEF
18	0.978 24.85	0.094 2.39	1.3121 33.33	0.415 10.54	1.233 31.32	1.1/16 - 18NEF
20	1.048 26.62	0.102 2.59	1.437 36.50	0.535 13.59	1.358 34.50	1.3/16 - 18NEF
22	1.048 26.62	0.102 2.59	1.562 39.68	0.535 13.59	1.483 37.67	1.5/16 - 18 NEF
24	1.048 26.62	0.102 2.59	1.687 42.85	0.572 14.53	1.610 40.90	1.7/16 - 18 NEF

# Single Mole Fixing Receptacles

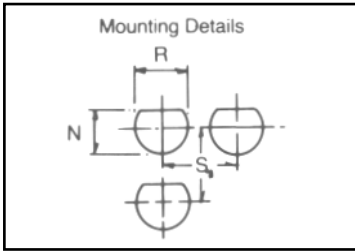

**5065**

**62G B-5065**  
BS9522-F0017 C2261

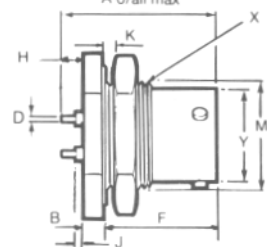
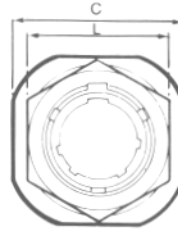

Single hole mounting with plain shell and film wire terminations

Shell Size	A max	B ± 0.005 (± 0.13)	C sq.	D max	F min ± 0.005 (± 0.13)	H max	J min ± 0.02 (± 0.51)	K min	L max	M -0.005 (-0.13)	N ± 0.005 (± 0.13)	R ± 0.005 (± 0.13)	S	Y	X Thread			
08	1.021 25.94	0.117 2.97	0.942 23.93	0.030 0.76	0.028 0.71	0.706 17.93	0.218 5.54	0.178 4.52	0.060 1.52	0.062 1.58	0.125 3.18	0.750 19.05	0.527 13.3	0.540 13.72	0.572 14.53	1.250 31.75	0.473 12.03	9/16 - 24 NEF
10	1.021 25.94	0.117 2.97	1.067 27.10	0.030 0.76	0.028 0.71	0.706 17.93	0.218 5.54	0.178 4.52	0.060 1.52	0.062 1.58	0.125 3.18	0.875 22.23	0.652 16.56	0.665 16.89	0.697 17.70	1.359 34.52	0.590 14.99	11/16 - 24 NEF
12	1.021 25.94	0.117 2.97	1.255 31.88	0.030 0.76	0.028 0.71	0.706 17.93	0.218 5.54	0.178 4.52	0.060 1.52	0.062 1.58	0.125 3.18	1.062 26.98	0.815 20.70	0.828 21.03	0.885 22.48	1.531 38.89	0.750 19.05	7/8 - 20 UNEF
14	1.021 25.94	0.117 2.97	1.380 35.05	0.030 0.76	0.028 0.71	0.706 17.93	0.218 5.54	0.178 4.52	0.060 1.52	0.062 1.58	0.125 3.18	1.187 30.15	0.939 23.85	0.952 24.18	1.010 25.65	1.656 42.06	0.875 22.23	1 - 20 UNEF
16	1.021 25.94	0.117 2.97	1.505 38.23	0.030 0.76	0.028 0.71	0.706 17.93	0.218 5.54	0.178 4.52	0.060 1.52	0.062 1.58	0.125 3.18	1.312 33.32	1.063 27.00	1.076 27.33	1.135 28.83	1.781 45.24	1.000 25.40	1.1/8 - 18 NEF
18	1.021 25.94	0.117 2.97	1.630 41.40	0.030 0.76	0.028 0.71	0.706 17.93	0.218 5.54	0.178 4.52	0.060 1.52	0.062 1.58	0.125 3.18	1.437 36.50	1.188 30.18	1.201 30.50	1.260 32.00	1.891 48.03	1.125 28.58	1.1/4 - 18 NEF
20	1.240 31.50	0.148 3.76	1.817 46.15	0.030 0.76	0.028 0.71	0.894 22.71	0.218 5.54	0.178 4.52	0.060 1.52	0.062 1.58	0.250 6.35	1.562 38.68	1.313 33.35	1.326 33.68	1.385 35.18	2.031 51.59	1.250 31.75	1.3/8 - 18 NEF
22	1.240 31.50	0.148 3.76	1.942 49.33	0.030 0.76	0.028 0.71	0.894 22.71	0.218 5.54	0.178 4.52	0.060 1.52	0.062 1.58	0.250 6.35	1.687 42.85	1.438 36.53	1.451 36.85	1.510 38.35	2.156 54.76	1.375 34.93	1.1/2 - 18 NEF
24	1.273 32.34	0.148 3.76	2.067 52.50	0.030 0.76	0.028 0.71	0.927 23.55	0.218 5.54	0.178 4.52	0.060 1.52	0.062 1.58	0.250 6.35	1.812 46.05	1.563 39.70	1.576 40.03	1.635 41.45	2.277 57.84	1.500 38.10	1.5/8 - 18 NEF



**5067**

**62GB-5067**  
BS9522 - F0017 - C2261

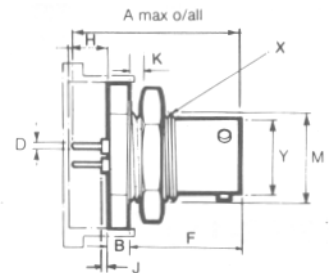
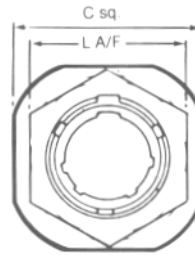





Single hole mounting with plain shell and film wire terminations

Shell Size	A max	B ± 0.005 (± 0.13)	C max sq.	D max	F min ± 0.005 (± 0.13)	H max	J min ± 0.012 (± 0.30)	K min	L max	M -0.005 (-0.13)	N ± 0.005 (± 0.13)	R ± 0.005 (± 0.13)	S	Y	X Thread			
08	1.095 27.81	0.117 2.97	0.942 23.93	0.030 0.76	0.028 0.71	0.706 17.93	0.262 6.66	0.230 5.85	0.049 1.24	0.062 1.58	0.125 3.18	0.750 19.05	0.527 13.3	0.540 13.72	0.572 14.53	1.250 31.75	0.473 12.03	9/16 - 24 NEF
10	1.095 27.81	0.117 2.97	1.067 27.10	0.030 0.76	0.028 0.71	0.706 17.93	0.262 6.66	0.230 5.85	0.049 1.24	0.062 1.58	0.125 3.18	0.875 22.23	0.652 16.56	0.665 16.89	0.697 17.70	1.359 34.52	0.590 14.99	11/16 - 24 NEF
12	1.095 27.81	0.117 2.97	1.255 31.88	0.030 0.76	0.028 0.71	0.706 17.93	0.262 6.66	0.230 5.85	0.049 1.24	0.062 1.58	0.125 3.18	1.062 26.98	0.815 20.70	0.828 21.03	0.885 22.50	1.531 38.89	0.750 19.05	7/8 - 20 UNEF
14	1.095 27.81	0.117 2.97	1.380 35.10	0.030 0.76	0.028 0.71	0.706 17.93	0.262 6.66	0.230 5.85	0.049 1.24	0.062 1.58	0.125 3.18	1.187 30.15	0.939 23.85	0.952 24.18	1.010 25.65	1.656 42.06	0.875 22.23	1 - 20 UNEF
16	1.095 27.81	0.117 2.97	1.505 38.23	0.030 0.76	0.028 0.71	0.706 17.93	0.262 6.66	0.230 5.85	0.049 1.24	0.062 1.58	0.125 3.18	1.312 33.32	1.063 27.00	1.076 27.33	1.135 28.83	1.781 45.24	1.000 25.40	1.1/8 - 18 NEF
18	1.095 27.81	0.117 2.97	1.630 41.40	0.030 0.76	0.028 0.71	0.706 17.93	0.262 6.66	0.230 5.85	0.049 1.24	0.062 1.58	0.125 3.18	1.437 36.50	1.188 30.18	1.201 30.50	1.260 32.00	1.891 48.03	1.125 28.58	1.1/4 - 18 NEF
20	1.309 33.24	0.148 3.76	1.817 46.15	0.030 0.76	0.028 0.71	0.894 22.71	0.262 6.66	0.230 5.85	0.049 1.24	0.062 1.58	0.250 6.35	1.562 38.68	1.313 33.35	1.326 33.68	1.385 35.18	2.031 51.59	1.250 31.75	1.3/8 - 18 NEF
22	1.309 33.24	0.148 3.76	1.942 49.33	0.030 0.76	0.028 0.71	0.894 22.71	0.262 6.66	0.230 5.85	0.049 1.24	0.062 1.58	0.250 6.35	1.687 42.85	1.438 36.53	1.451 36.86	1.510 38.35	2.156 54.76	1.375 34.93	1.1/2 - 18 NEF
24	1.342 34.08	0.148 3.76	2.067 52.50	0.030 0.76	0.028 0.71	0.927 23.55	0.262 6.66	0.230 5.85	0.049 1.24	0.062 1.58	0.250 6.35	1.812 46.03	1.563 39.07	1.576 40.03	1.635 41.59	2.277 57.84	1.500 38.10	1.5/8 - 18 NEF

# Cable Mounting Receptacles

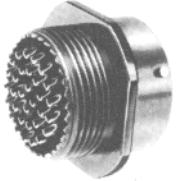
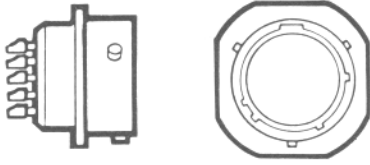
## Table of Styles

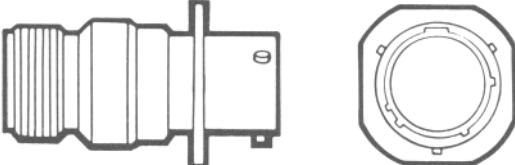
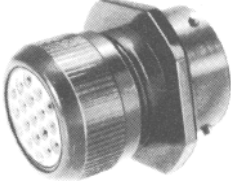
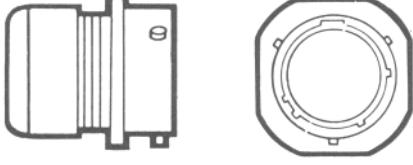
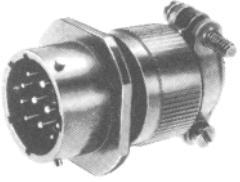
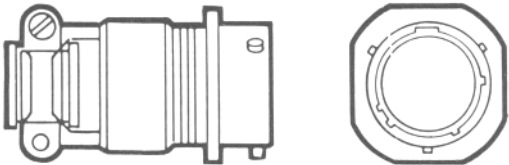
Page No.

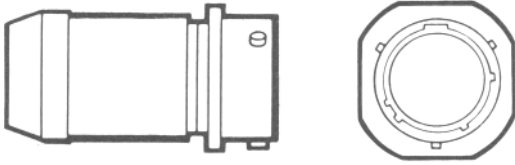
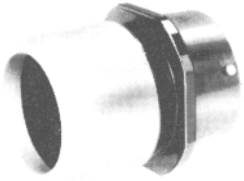
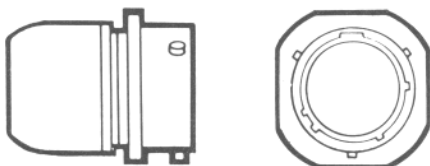
62GB-51T			29
62GB-11A			29
62GB-11E			30
62GB-11F			30
62GB-11J			31
62GB-11P			31

# Cable Mounting Receptacles

51T

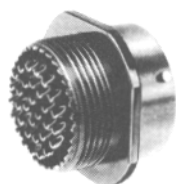

**62GB-51T**  
**BS9522-F0017-C2101**

Basic cable mounting receptacle with threaded shell to accept standard cable accessories.

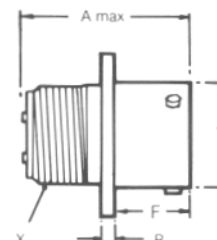
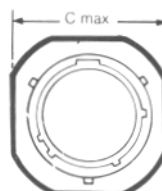

Shell Size	A max	B ± 0.005 (± 0.13)	C max sq	F ± 0.005 (± 0.13)	Y dia max	X Thread
08	0.978 24.84	0.094 2.39	0.817 20.75	0.415 10.54	0.473 12.03	7/16 - 28 UNEF
10	0.978 24.84	0.094 2.39	0.942 23.93	0.415 10.54	0.590 14.99	9/16 - 24 NEF
12	0.978 24.84	0.094 2.39	1.036 26.32	0.415 10.54	0.750 19.05	11/16 - 24 NEF
14	0.978 24.84	0.094 2.39	1.130 28.70	0.415 10.54	0.875 22.23	13/16 - 20 UNEF
16	0.978 24.84	0.094 2.39	1.223 31.07	0.415 10.54	1.000 25.40	15/16 - 20 UNEF
18	0.978 24.84	0.094 2.39	1.317 33.45	0.415 10.54	1.125 28.58	1.1/16 - 18 NEF
20	1.048 26.62	0.102 2.59	1.442 36.63	0.535 13.59	1.250 31.75	1.3/16 - 18 NEF
22	1.048 26.62	0.102 2.59	1.567 39.80	0.535 13.59	1.375 34.93	1.5/16 - 18 NEF
24	1.048 26.62	0.102 2.59	1.692 42.98	0.560 / 0.574 14.23 / 14.58	1.500 38.10	1.7/16 - 18 NEF

11A



**62GB-11A**

Cable mounting receptacle with general duty back shell. No grommet supplied.

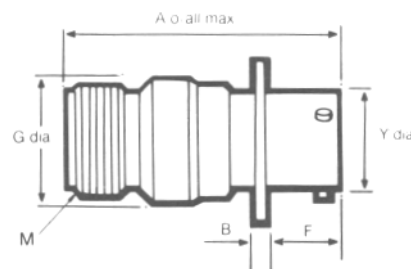
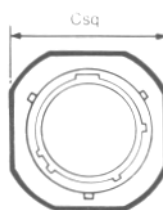

Shell Size	A max	B ± 0.005 (± 0.13)	C max sq	F ± 0.005 (± 0.13)	G dia max	Y Dia max	M Thread
08	1.624 41.25	0.094 2.39	0.817 20.75	0.415 10.54	0.561 14.25	0.473 12.03	1/2 - 28 UNEF
10	1.624 41.25	0.094 2.39	0.942 23.93	0.415 10.54	0.686 17.43	0.590 14.99	5/8 - 24 NEF
12	1.624 41.25	0.094 2.39	1.036 26.32	0.415 10.54	0.811 20.60	0.750 19.05	3/4 - 20 UNEF
14	1.624 41.25	0.094 2.39	1.130 28.70	0.415 10.54	0.936 23.78	0.875 22.23	7/8 - 20 UNEF
16	1.624 41.25	0.094 2.39	1.223 31.07	0.415 10.54	1.061 26.95	1.000 25.40	1 - 20 UNEF
18	1.624 41.25	0.094 2.39	1.317 33.45	0.415 10.54	1.186 30.13	1.125 28.58	1.3/16 - 18 NEF
20	1.687 42.85	0.104 / 0.100 2.64 / 2.55	1.442 36.63	0.535 13.59	1.311 33.30	1.250 31.75	1 3/16 - 18 NEF
22	1.687 42.85	0.104 / 0.100 2.64 / 2.55	1.567 39.80	0.535 13.59	1.436 36.75	1.375 34.93	1.7/16 - 18 NEF
24	1.730 43.94	0.104 / 0.100 2.64 / 2.55	1.692 42.98	0.569 / 0.574 14.45 / 14.58	1.561 39.65	1.500 38.10	1.7/16 - 18 NEF



# Cable Mounting Receptacles



**62GB-11E**  
MIL-C-26482 MS3111E

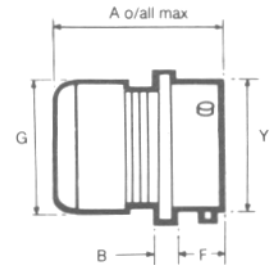
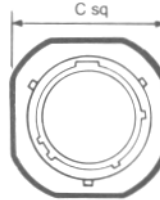

Cable mounting receptacle with grommet and grommet nut

Shell Size	A max	B ± 0.005 (± 0.13)	C max sq	F ± 0.005 (± 0.13)	G dia max	Y dia max
08	1.281	0.094	0.817	0.415	0.561	0.473
	32.54	2.39	20.75	10.54	14.25	12.03
10	1.281	0.094	0.942	0.415	0.686	0.590
	32.54	2.39	23.93	10.54	17.43	14.99
12	1.281	0.094	1.036	0.415	0.811	0.750
	32.54	2.39	26.32	10.54	20.60	19.05
14	1.281	0.094	1.130	0.415	0.936	0.875
	32.54	2.39	28.70	10.54	23.78	22.23
16	1.281	0.094	1.223	0.415	1.061	1.000
	32.54	2.39	31.07	10.54	26.95	25.40
18	1.281	0.094	1.317	0.415	1.186	1.125
	32.54	2.39	33.45	10.54	30.13	28.58
20	1.383	0.102	1.442	0.535	1.311	1.250
	35.13	2.59	36.63	13.59	33.30	31.75
22	1.383	0.102	1.567	0.535	1.436	1.375
	35.13	2.59	39.80	13.59	36.75	34.93
24	1.383	0.102	1.692	0.569 / 0.574	1.561	1.500
	35.13	2.59	42.98	14.45 / 14.58	39.65	38.10



**62GB-11F**  
MIL-C-26482 MS3111F

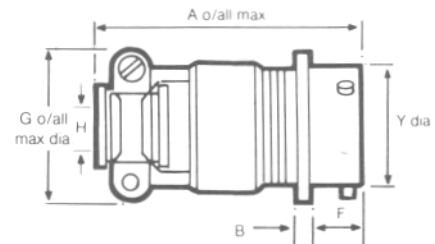
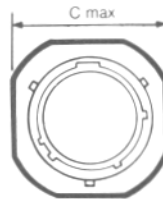

Cable mounting receptacle with grommet and grommet nut fitted with integral strain relief clamp

Shell Size	A max	B ± 0.005 (± 0.13)	C max sq	F ± 0.005 (± 0.13)	G dia max	H ± 0.005 (± 0.13)	Y dia max
08	1.762	0.094	0.817	0.415	0.828	0.156	0.473
	44.75	2.39	20.75	10.54	21.03	3.96	12.03
10	1.762	0.094	0.942	0.415	0.891	0.188	0.590
	44.75	2.39	23.93	10.54	22.63	4.78	14.99
12	1.762	0.094	1.036	0.415	1.016	0.312	0.750
	44.75	2.39	26.32	10.54	25.81	7.93	19.05
14	1.736	0.094	1.130	0.415	1.141	0.375	0.875
	44.10	2.39	28.70	10.54	28.97	9.53	22.23
16	1.876	0.094	1.223	0.415	1.203	0.500	1.000
	47.65	2.39	31.07	10.54	30.56	12.7	25.40
18	1.876	0.094	1.317	0.415	1.426	0.625	1.125
	47.65	2.39	33.45	10.54	36.22	15.88	28.58
20	2.118	0.104 / 0.100	1.442	0.535	1.426	0.625	1.250
	53.80	2.64 / 2.55	36.63	13.59	36.22	15.88	31.75
22	2.118	0.104 / 0.100	1.567	0.535	1.567	0.750	1.375
	53.80	2.64 / 2.55	39.80	13.59	39.80	19.05	34.93
24	2.250	0.104 / 0.100	1.692	0.569 / 0.574	1.735	0.800	1.500
	57.15	2.64 / 2.55	42.98	14.45 / 14.58	44.07	20.32	38.10

# Cable Mounting Receptacles

11J

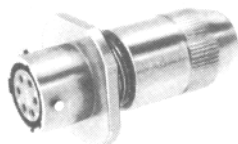

62GB-11J

With cable clamp for unscreened jacketed cable. No grommet supplied

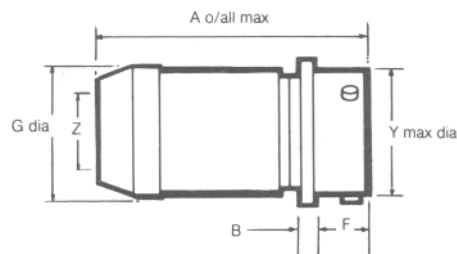
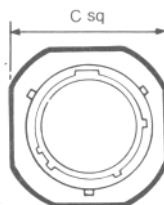

Shell Size	A max	B ± 0.005 (± 0.13)	C max sq	F ± 0.005 (± 0.13)	G dia max	Y dia max	min closed	Z max free
08	1.846	0.094	0.817	0.415	0.561	0.473	0.168	0.230
	46.89	2.39	20.75	10.54	14.25	12.03	4.28	5.84
10	1.846	0.094	0.942	0.415	0.686	0.590	0.205	0.312
	46.89	2.39	23.93	10.54	17.43	14.99	5.21	7.93
12	1.947	0.094	1.036	0.415	0.811	0.750	0.338	0.442
	49.45	2.39	26.32	10.54	20.60	19.05	8.59	11.23
14	2.147	0.094	1.130	0.415	0.936	0.875	0.416	0.539
	54.54	2.39	28.70	10.54	23.78	22.23	10.57	13.69
16	2.347	0.094	1.223	0.415	1.061	1.000	0.550	0.616
	59.61	2.39	31.07	10.54	26.95	25.40	13.97	15.65
18	2.547	0.094	1.317	0.415	1.186	1.125	0.600	0.672
	64.70	2.39	33.45	10.54	30.13	28.58	15.24	17.07
20	2.831	0.102	1.442	0.535	1.311	1.250	0.635	0.747
	71.91	2.59	36.63	13.59	33.30	31.75	16.13	18.98
22	3.031	0.102	1.567	0.535	1.436	1.375	0.670	0.846
	76.99	2.59	39.80	13.59	36.75	34.93	17.02	21.49
24	3.074	0.102	1.692	0.569 / 0.574	1.561	1.500	0.740	0.894
	78.03	2.59	42.98	14.45 / 14.58	39.65	38.10	18.80	22.71

11P

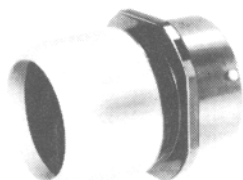

62GB-11P  
MIL-C-26482 MS3111P

For potted seal supplied complete with detachable potting mould and location ring

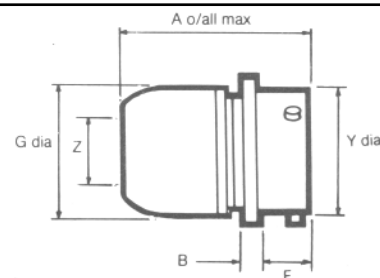
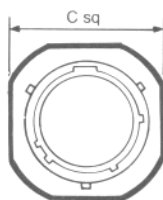



Shell Size	A max	B ± 0.005 (± 0.13)	C max sq	F ± 0.005 (± 0.13)	G dia max	Y dia max	Z min
08	1.316	0.094	0.817	0.415	0.572	0.473	0.260
	33.43	2.39	20.75	10.54	14.53	12.03	6.60
10	1.425	0.094	0.942	0.415	0.666	0.590	0.463
	36.20	2.39	23.93	10.54	16.92	14.99	11.76
12	1.394	0.094	1.036	0.415	0.822	0.750	0.557
	35.41	2.39	26.32	10.54	20.88	19.05	14.15
14	1.394	0.094	1.130	0.415	0.907	0.875	0.590
	35.41	2.39	28.70	10.54	23.04	22.23	14.99
16	1.394	0.094	1.223	0.415	1.040	1.000	0.713
	35.41	2.39	31.07	10.54	26.42	25.40	18.11
18	1.394	0.094	1.317	0.415	1.165	1.125	0.835
	35.41	2.39	33.45	10.54	29.59	28.58	22.21
20	1.612	0.102	1.442	0.535	1.285	1.250	1.015
	40.95	2.59	36.63	13.59	32.64	31.75	25.78
22	1.612	0.102	1.567	0.535	1.400	1.375	1.015
	40.95	2.59	39.80	13.59	35.56	34.93	25.78
24	1.674	0.102	1.692	0.569 / 0.574	1.540	1.500	1.265
	42.52	2.59	42.98	14.45 / 14.58	39.12	38.10	32.13

# Plugs

## Table of Styles

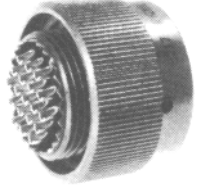
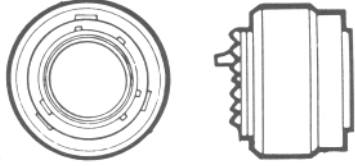
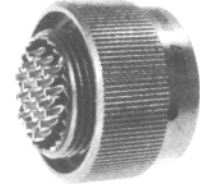
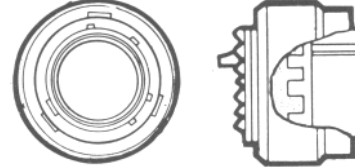
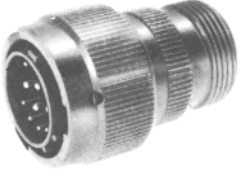
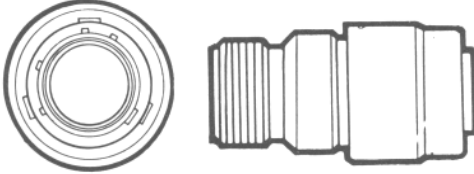
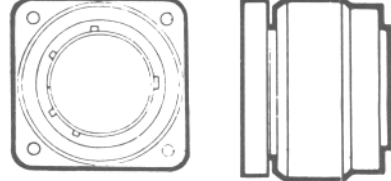
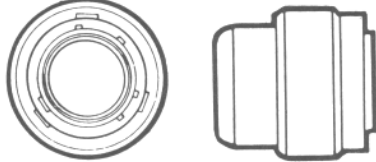
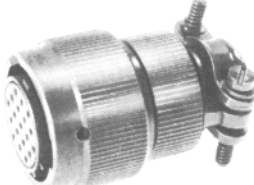
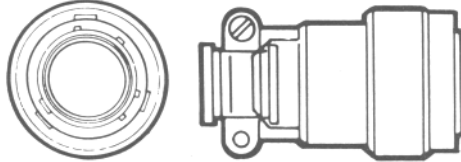
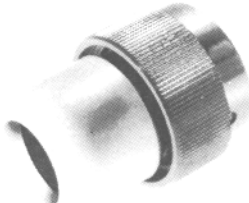



Page No.

62GB-56T			34
62GB-56TG			34
62GB-16A			35
62GB-56T (046)			35
62GB-16E			36
62GB-16F			36
62GB-16P			37

# Plugs

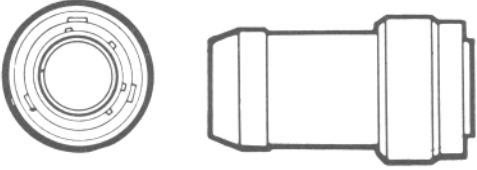
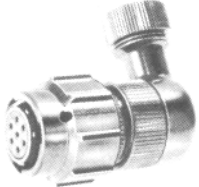
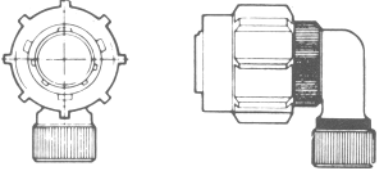
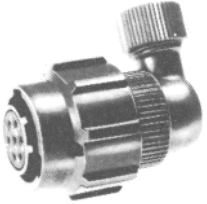
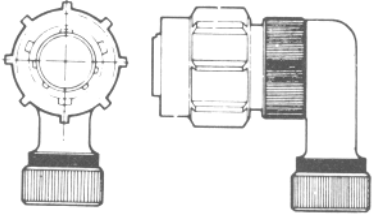
## Table of Styles

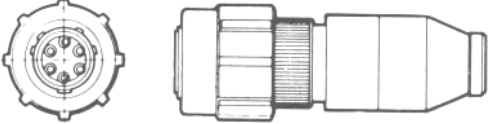
Page No.

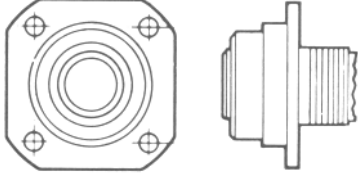
62GB-16J			37
62GB-5039-10			38
62GB-5055-10			38
62GB-5056-10			38
62GB-5074			39

# Plugs

**56T**

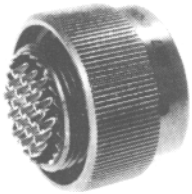

**62GB-56T**  
BS9522 F0017 C2092

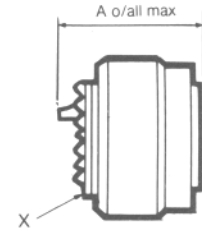
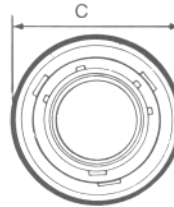

Basic plug with threaded shell to accept standard cable accessories

Shell Size	A Max	C max	X Thread
08	0.976 24.79	0.750 19.05	7/16 - 28 UNEF
10	0.976 24.79	0.859 21.82	9/16 - 24 NEF
12	0.976 24.79	1.031 26.19	11/16 -24NEF
14	0.976 24.79	1.156 29.36	13/16 - 20 UNEF
16	0.976 24.79	1.281 32.54	15/16 - 20 UNEF
18	0.976 24.79	1.391 35.33	1.1 /16 - 18 NEF
20	0.976 24.79	1.531 38.89	1.3/16 - 18 NEF
22	0.976 24.79	1.656 42.06	1.5/16 - 18 NEF
24	0.976 24.79	1.777 45.14	1.7/16 - 18 NEF

**56TG**

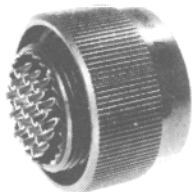

**62GB-56TG**  
BS9522 F001 7 C2093

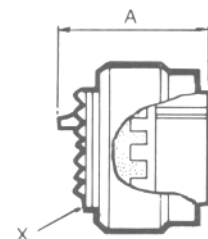
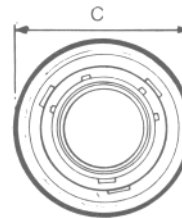

Basic plug with threaded shell to accept standard cable accessories. Has shell grounding spring fingers

Shell Size	A max	C max	X Thread
08	0.976 24.79	0.750 19.05	7/16 - 28 UNEF
10	0.976 24.79	0.859 21.82	9/16 - 24 NEF
12	0.976 24.79	1.031 26.19	11/16 - 24 NEF
14	0.976 24.79	1.156 29.36	13/16 - 20 UNEF
16	0.976 24.79	1.281 32.54	15/16 - 20 UNEF
18	0.976 24.79	1.391 35.33	1.1 /16 - 18 NEF
20	0.976 24.79	1.531 38.89	1.3/16 - 18 NEF
22	0.976 24.79	1.656 42.06	1.5/16 - 18 NEF
24	0.976 24.79	1.777 45.14	11/16 - 18 NEF

# Plugs

**16A**



**62GB-1 6A**

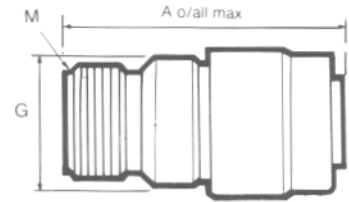

Plug with general duty back shell.  
No grommet provided.

Shell Size	A max	C max	G max	M Thread
08	1.614 41.00	0.750 19.05	0.561 14.25	1/2 - 28 UNEF
10	1.614 41.00	0.859 21.82	0.686 17.43	5/8 - 24 NEF
12	1.614 41.00	1.031 26.19	0.811 20.60	3/4 - 20 UNEF
14	1.614 41.00	1.156 29.36	0.936 23.78	7/8 - 20 UNEF
16	1.614 41.00	1.281 32.54	1.061 26.95	1 - 20 UNEF
18	1.614 41.00	1.391 35.33	1.186 30.13	1.3/16 - 18 NEF
20	1.614 41.00	1.531 38.89	1.311 33.30	1.3/16 - 18 NEF
22	1.614 41.00	1.656 42.06	1.436 36.75	1.7/16 - 18 NEF
24	1.658 42.11	1.777 45.14	1.561 39.65	1.7116 - 18 NEF

**56T**



**62GB-56T(046)**

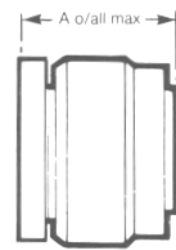
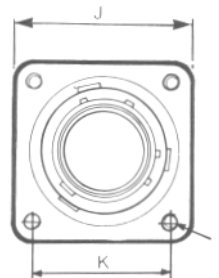

Box-mounting plug. Available for shell size 16:  
other sizes to special order. Cable accessories  
cannot be fitted.

Shell Size	A max	J max	K	L
16	1.042 26.47	1.317 33.45	1.000 25.40	6.32 NC
20	1.042 26.47	1.625 41.28	1.250 31.75	6.32 NC
22	1.042 26.47	1.625 41.28	1.250 31.75	6.32 NC

# Plugs

**16E**

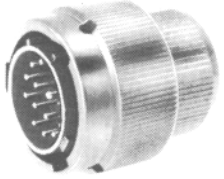

**62GB-16E**  
MIL - C26482 MS3116E

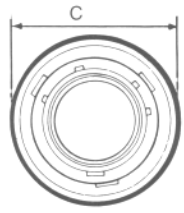

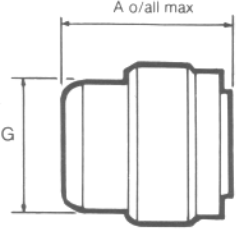

Plug with grommet and grommet nut

Shell Size	A max	C max	G max
08	1.281	0.750	0.561
	32.54	1.05	14.25
10	1.281	0.859	0.686
	32.54	21.82	17.431
12	1.281	1.031	0.811
	32.54	26.19	20.60
14	1.281	1.156	0.936
	32.54	29.36	23.78
16	1.281	1.281	1.061
	32.54	32.54	26.95
18	1.281	1.391	1.186
	32.54	35.33	30.13
20	1.281	1.531	1.311
	32.54	38.89	33.30
22	1.281	1.656	1.436
	32.54	42.06	36.75
24	1.281	1.777	1.561
	32.54	45.14	39.65

**16F**

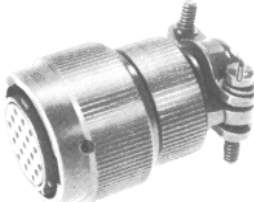

**62GB-16F**  
MIL - C26482 MS3116F

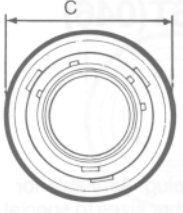

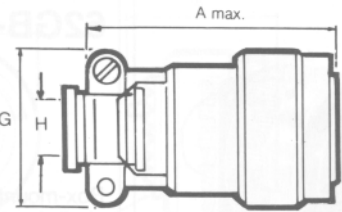

Plug with grommet and grommet nut fitted with integral strain relief clamp.

Shell Size	A max	C dia max	G dia max	H ± 0.005 (± 0.13)
08	1.752	0.750	0.828	0.156
	44.50	19.05	21.03	3.96
10	1.752	0.859	0.891	0.188
	44.50	21.82	22.63	4.78
12	1.752	1.031	1.016	0.312
	44.50	26.19	25.81	7.93
14	1.726	1.156	1.141	0.375
	43.84	29.36	28.97	9.53
16	1.866	1.281	1.203	0.500
	47.40	32.54	30.56	12.70
18	1.866	1.391	1.426	0.625
	47.40	35.33	36.22	15.88
20	2.040	1.531	1.426	0.625
	51.81	38.89	36.22	15.88
22	2.040	1.656	1.567	0.750
	51.81	42.06	39.80	19.05
24	2.178	1.777	1.735	0.800
	55.32	45.14	44.07	20.32

# Plugs

**16P**

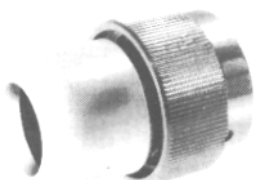

**62GB-16P**  
MIL-C26482 MS3116P

For potted seal. Supplied complete with detachable potting mould and location ring.

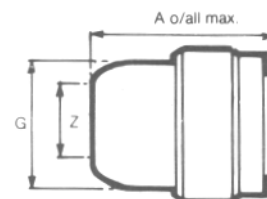
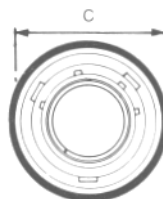

Shell Size	A	C	G	Z
	max	max	max	min
08	1.306	0.750	0.572	0.260
	33.17	19.05	14.53	6.60
10	1.415	0.859	0.666	0.463
	35.94	21.82	16.92	11.76
12	1.384	1.031	0.822	0.557
	35.15	26.19	20.88	14.14
14	1.384	1.156	0.907	0.590
	35.15	29.36	23.04	14.99
16	1.384	1.281	1.040	0.713
	35.15	32.54	26.41	18.11
18	1.384	1.391	1.165	0.835
	35.15	35.33	29.59	22.21
20	1.539	1.531	1.285	1.015
	39.09	38.89	32.64	25.78
22	1.539	1.656	1.400	1.015
	39.09	42.06	35.56	25.78
24	1.602	1.777	1.540	1.265
	40.69	45.14	39.12	32.13

**16J**

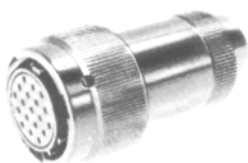

**62GB - 16J**

Plug with cable clamp for unscreened jacketed cable. No grommet supplied.

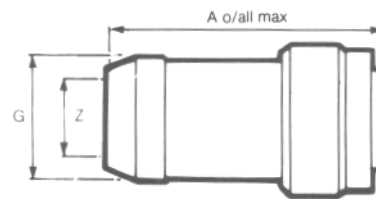
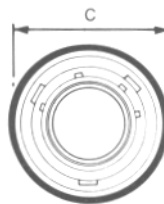

Shell Size	A	C	G	Z
	max	max	max	min max
08	1.836	0.750	0.561	0.168 0.230
	46.64	19.05	14.25	4.28 5.84
10	1.836	0.859	0.686	0.205 0.312
	46.64	21.82	17.43	5.21 7.93
12	1.937	1.031	0.811	0.388 0.442
	49.20	26.19	20.60	8.59 11.23
14	2.137	1.156	0.936	0.416 0.539
	54.28	29.36	23.78	10.57 13.69
16	2.337	1.281	1.061	0.550 0.616
	59.36	32.54	26.95	13.97 15.65
18	2.537	1.391	1.186	0.600 0.672
	64.45	35.33	30.13	15.24 17.07
20	2.758	1.531	1.311	0.635 0.747
	70.05	38.89	33.30	16.13 18.98
22	2.958	1.656	1.436	0.670 0.846
	75.13	42.06	36.75	17.02 21.49
24	3.002	1.777	1.561	0.740 0.894
	76.25	45.14	39.65	18.80 22.71



# Plugs

**5039**



**62GB-5039-10**

SD/C 235 155 - X  
SD/C 235 156 - X

Low profile, solder termination plug with 90° screened cable outlet.

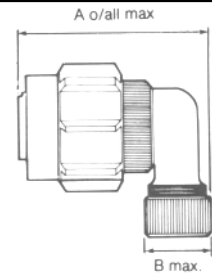
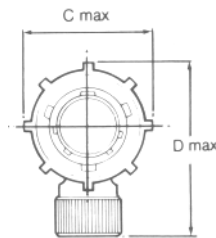

Shell Size	A max	B max	C max	D max
10	1.473 37.41	0.500 12.70	0.980 24.89	1.500 38.10

**5055**

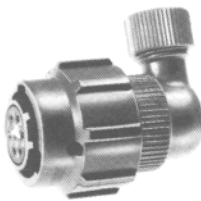

**62GB-5055-10**

SD/2 235 193 - X

Low profile solder termination plug with size 12 90° screened cable outlet.

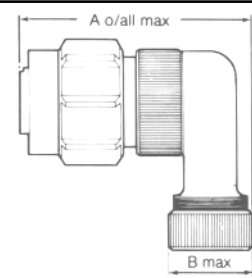
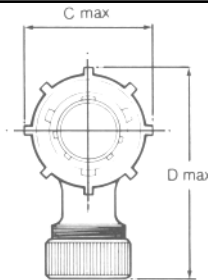

Shell Size	A max	B max	C max	D max
10	1.800 45.72	0.655 16.64	0.980 24.89	1.800 45.72

**5056**



**62GB-5056-10**

Audio plug with solder termination

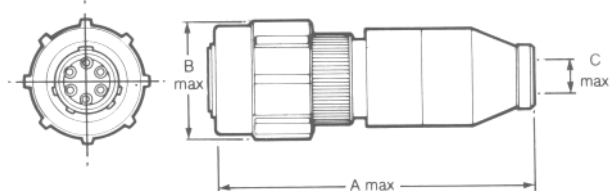

Shell Size	A max	B max	C max
10	2.375 60.33	0.979 / 0.969 24.87 / 24.61	0.310 7.87

# Plugs

**5074**



**62GB-5074**

Flange mounting push/pull plug with threaded shell to accept standard cable accessories.

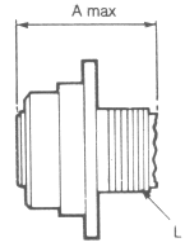
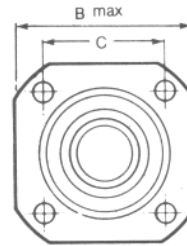













Shell Size	A max	B max	C	L
10	0.912	1.125	0.866	9/16 - 24 NEF
	23.17	28.57	22.00	
12	0.912	1.218	0.969	9/16 - 24 NEF
	23.17	30.93	24.61	
14	0.912	1.312	1.062	9/16 - 24 NEF
	23.17	33.32	26.97	

# Accessories

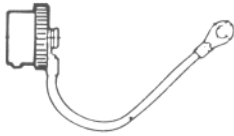
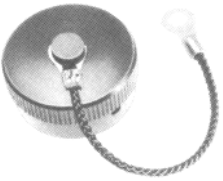
## Table of Styles







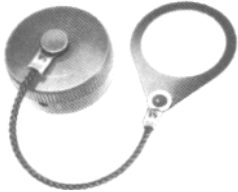
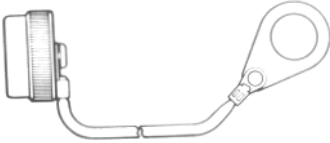

Page No.

62GB-736			42
62GB-737			42
62GB-738			43
62GB-742			43
62GB-810			44
62GB-812			44
62GB-813			45

# Accessories

## Table of Styles

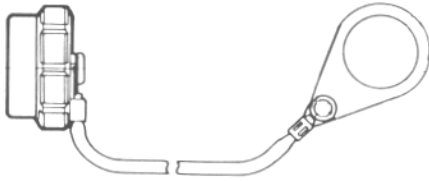
Page No.

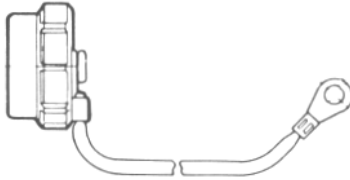
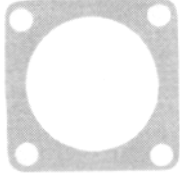
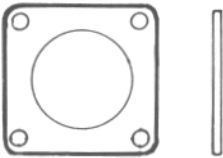
62GB-814			45
62GB-997			46
62GB-998			46
62GB-1069			47
62GB-1070			47
62GB-760			48

# Accessories

**736**



**62GB-736**

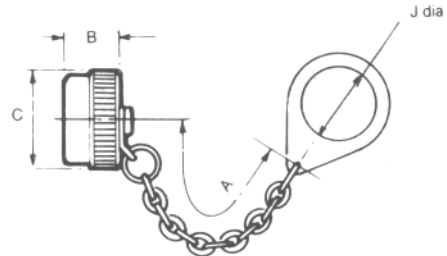

Caps and chains for single hole mounting receptacles

Shell Size	A $\pm 0.25$ ( $\pm 6.35$ )	B $\pm 0.005$ ( $\pm 0.13$ )	C dia max	J $\pm 0.005$ ( $\pm 0.127$ )
08	3.0 76.2	0.521 13.23	0.734 18.64	0.578 14.68
10	3.0 76.2	0.521 13.23	0.859 21.82	0.703 17.86
12	3.5 88.9	0.521 13.23	1.000 25.4	0.891 22.63
14	3.5 88.9	0.521 13.23	1.125 28.57	1.016 25.81
16	3.5 88.9	0.521 13.23	1.250 31.75	1.141 29.39
18	3.5 88.9	0.521 13.23	1.375 34.92	1.266 32.16
20	4.0 101.6	0.521 13.23	1.500 38.1	1.391 35.33
22	4.0 101.6	0.521 13.23	1.625 41.27	1.516 38.51
24	4.0 101.6	0.556 14.12	1.750 44.45	1.641 41.68

**737**

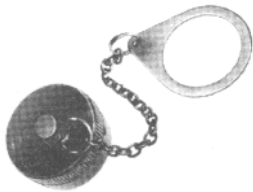

**62GB-737**

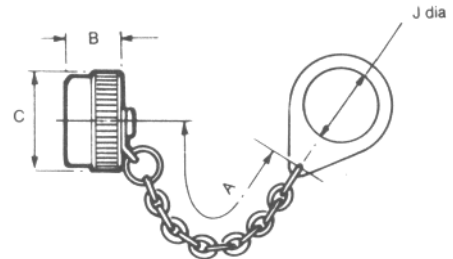

Caps and chains for cable mounting receptacles.

Shell Size	A $\pm 0.25$ ( $\pm 6.35$ )	B $\pm 0.005$ ( $\pm 0.13$ )	C dia max	J $\pm 0.005$ ( $\pm 0.127$ )
08	3.0 76.2	0.521 13.23	0.734 18.64	0.458 11.63
10	3.0 76.2	0.521 13.23	0.859 21.82	0.583 14.81
12	3.5 88.9	0.521 13.23	1.000 25.4	0.708 17.98
14	3.5 88.9	0.521 13.23	1.125 28.57	0.896 22.76
16	3.5 88.9	0.521 13.23	1.250 31.75	1.021 25.93
18	3.5 88.9	0.521 13.23	1.375 34.92	1.146 29.11
20	4.0 101.6	0.521 13.23	1.500 38.1	1.271 32.28
22	4.0 101.6	0.521 13.23	1.625 41.27	1.396 35.46
24	4.0 101.6	0.556 14.12	1.750 44.45	1.521 38.63

# Accessories

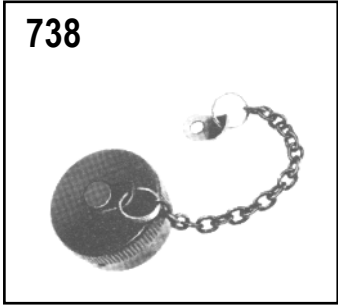

**62GB-738**

Caps and chains for flange mounting receptacles.

Shell Size	A ± 0.25 (± 6.35)	B ± 0.005 (± 0.13)	C dia max	J ± 0.005 (± 0.127)
08	3.0 76.2	0.521 13.23	0.734 18.64	0.125 3.18
10	3.0 76.2	0.521 13.23	0.859 21.82	0.125 3.18
12	3.5 88.9	0.521 13.23	1.000 25.4	0.125 3.18
14	3.5 88.9	0.521 13.23	1.125 28.57	0.125 3.18
16	3.5 88.9	0.521 13.23	1.250 31.75	0.125 3.18
18	3.5 88.9	0.521 13.23	1.375 34.92	0.125 3.18
20	4.0 101.6	0.521 13.23	1.500 38.1	0.125 3.18
22	4.0 101.6	0.521 13.23	1.625 41.27	0.125 3.18
24	4.0 101.6	0.556 14.12	1.750 44.45	0.152 3.86



**62GB-742**

Caps and chains for plugs.

Shell Size	A ± 0.25 (± 6.35)	B ± 0.005 (± 0.13)	C dia max	J ± 0.005 (± 0.127)
08	3.0 76.2	0.522 13.25	0.719 18.26	0.125 3.18
10	3.0 76.2	0.522 13.25	0.844 21.43	0.125 3.18
12	3.5 88.9	0.522 13.25	1.000 25.4	0.125 3.18
14	3.5 88.9	0.522 13.25	1.125 28.57	0.125 3.18
16	3.5 88.9	0.522 13.25	1.250 31.75	0.125 3.18
18	3.5 88.9	0.522 13.25	1.357 34.92	0.125 3.18
20	4.0 101.6	0.584 14.83	1.500 38.1	0.125 3.18
22	4.0 101.6	0.584 14.83	1.625 41.27	0.125 3.18
24	4.0 101.6	0.617 15.67	1.750 44.45	0.152 3.86

# Accessories

810



**62GB-810**  
BS9522-F0017-A2012

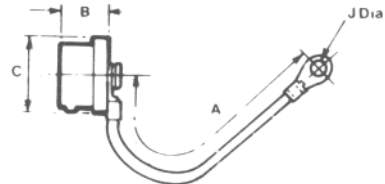

Caps and cords for plugs

Shell Size	A ± 0.25 (± 6.35)	B ± 0.005 (± 0.13)	C dia max	J ± 0.003 (± 0.08)
08	3.0 76.2	0.522 13.25	0.719 18.26	0.145 3.68
10	3.0 76.2	0.522 13.25	0.844 21.43	3.685 3.68
12	3.5 88.9	0.522 13.25	1.000 25.4	0.145 3.68
14	3.5 88.9	0.522 13.25	1.125 28.57	0.145 3.68
16	3.5 88.9	0.522 13.25	1.250 31.75	0.145 3.68
20	4.0 101.6	0.584 14.83	1.500 38.1	0.145 3.68
22	4.0 101.6	0.584 14.83	1.625 41.27	0.145 3.68
24	4.0 101.6	0.617 15.67	1.750 44.45	0.171 4.34

812

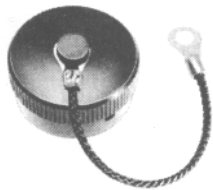

**62GB-812**  
BS9522-F0017-A2013

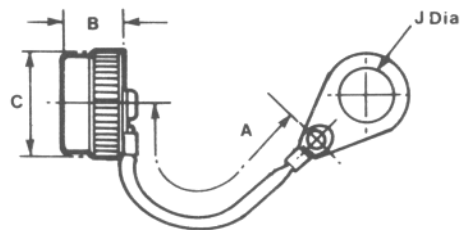

Caps and cords for flange mounting receptacles.

Shell Size	A ± 0.25 (± 6.35)	B ± 0.005 (± 0.13)	C dia max	J ± 0.003 (± 0.08)
08	3.0 76.2	0.521 13.23	0.734 18.64	0.145 3.68
10	3.0 76.2	0.521 13.23	0.859 21.82	0.145 3.68
12	3.5 88.9	0.521 13.23	1.000 25.4	0.145 3.68
14	3.5 88.9	0.521 13.23	1.125 28.57	0.145 3.68
16	3.5 88.9	0.521 13.23	1.250 31.75	0.145 3.68
18	3.5 88.9	0.521 13.23	1.375 34.92	0.145 3.68
20	4.0 101.6	0.521 13.23	1.500 38.1	0.145 3.68
22	4.0 101.6	0.521 13.23	1.625 41.27	0.145 3.68
24	4.0 101.6	0.556 14.12	1.750 44.45	0.171 4.34

# Accessories

**813**



**62GB-813**  
BS9522-F0017 A2014

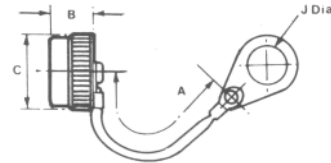

Caps and cords for single hole mounting receptacles.

Shell Size	A ± 0.25 (± 6.35)	B ± 0.005 (± 0.13)	C max	J + 0.010 (+ 0.25)
08	3.0	0.521	0.734	0.578
	76.2	13.23	18.64	14.68
10	3.0	0.521	0.859	0.703
	76.2	13.23	21.82	17.86
12	3.5	0.521	1.000	0.891
	88.9	13.23	25.4	22.63
14	3.5	0.521	1.125	1.016
	88.9	13.23	28.57	25.81
16	3.5	0.521	1.250	1.141
	88.9	13.23	31.75	29.39
18	3.5	0.521	1.375	1.266
	88.9	13.23	34.92	32.16
20	4.0	0.521	1.500	1.391
	101.0	13.23	38.1	35.33
22	4.0	0.521	1.625	1.516
	101.6	13.23	41.27	38.56
24	4.0	0.556	1.750	1.641
	101.6	14.12	44.45	41.68

**814**



**62GB-814**

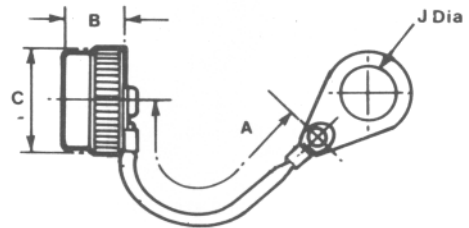

Caps and cords for cable mounting receptacles.

Shell Size	A ± 0.25 (± 6.35)	B ± 0.005 (± 0.13)	C max	J +0.010 (+ 0.25)
08	3.0	0.521	0.734	0.453
	76.2	13.23	18.64	11.50
10	3.0	0.521	0.859	0.578
	76.2	13.23	21.82	14.64
12	3.5	0.521	1.000	0.703
	88.9	13.23	25.4	17.85
14	3.5	0.521	1.125	0.891
	88.9	13.23	28.57	22.63
16	3.5	0.521	1.250	1.016
	88.9	13.23	31.75	25.80
18	3.5	0.521	1.375	1.141
	88.9	13.23	34.92	28.98
20	4.0	0.521	1.500	1.266
	101.6	13.23	38.1	32.15
22	4.0	0.521	1.625	1.391
	101.6	13.23	41.27	35.33
24	4.0	0.556	1.750	1.516
	101.6	14.12	44.45	38.50



# Accessories



**62GB-997**

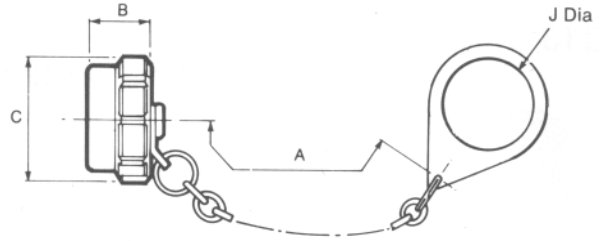

Caps and chains ribbed for single hole mounting receptacles.

Shell Size	A ± 0.25 (± 6.35)	B ± 0.005 (± 0.13)	C dia max	J + 0.010 (± 0.25)
08	3.0	0.521	0.892	0.578
	76.2	13.23	22.66	14.69
10	3.0	0.521	1.017	0.703
	76.2	13.23	26.84	17.86
12	3.5	0.521	1.142	0.891
	88.9	13.23	29.01	22.64
14	3.5	0.521	1.267	1.016
	88.9	13.23	32.19	25.81
16	3.5	0.521	1.454	1.141
	88.9	13.23	36.94	28.99
18	3.5	0.521	1.563	1.266
	88.9	13.23	39.70	32.16
20	4.0	0.521	1.687	1.391
	101.6	13.23	42.85	35.34
22	4.0	0.521	1.797	1.516
	101.6	13.23	45.65	38.51
24	4.0	0.556	1.922	1.641
	101.6	14.12	48.82	41.69



**62GB-998**

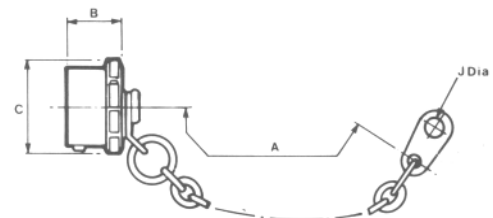

Caps and chains ribbed for plugs.

Shell Size	A ± 0.25 (± 6.35)	g max	C dia max	J ± 0.005 (± 0.13)
08	3.0	0.562	0.892	0.125
	76.2	14.28	22.66	3.18
10	3.0	0.562	1.017	0.125
	76.2	14.28	25.84	3.18
12	3.5	0.562	1.142	0.125
	88.9	14.28	29.01	3.18
14	3.5	0.562	1.267	0.125
	88.9	14.28	32.19	3.18
16	3.5	0.562	1.454	0.125
	88.9	14.28	36.94	3.18
18	3.5	0.562	1.563	0.125
	88.9	14.28	39.70	3.18
20	4.0	0.624	1.687	0.125
	101.6	15.85	42.85	3.18
22	4.0	0.624	1.797	0.125
	101.6	15.85	45.65	3.18
24	4.0	0.624	1.922	0.147
	101.6	15.85	48.82	3.74

# Accessories

**1069**



**62GB-1069**

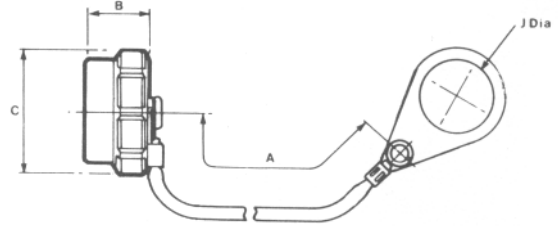

Caps and cords ribbed for single hole mounting receptacles.

Shell Size	A ± 0.25 (± 6.35)	B ± 0.005 (± 0.13)	C dia max	J + 0.010 (+ 0.25)
08	3.0 76.2	0.521 13.23	0.892 22.66	0.578 14.69
10	8.0 76.2	0.521 13.23	1.017 26.84	0.703 17.86
12	3.5 88.9	0.521 13.23	1.142 29.01	0.891 22.64
14	3.5 88.9	0.521 13.23	1.267 32.19	1.016 25.81
16	3.5 88.9	0.521 13.23	1.454 36.94	1.141 28.99
18	3.5 88.9	0.521 13.23	1.563 39.70	1.266 32.16
20	4.0 101.6	0.521 13.23	1.687 42.85	1.391 35.34
22	4.0 101.6	0.521 13.23	1.797 45.65	1.516 38.51
24	4.0 101.6	0.556 14.12	1.922 48.82	1.641 41.686

**1070**



**62GB-1070**

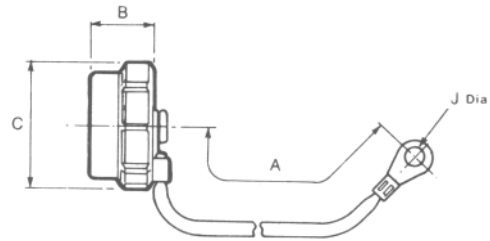

Caps and cords ribbed for flange mounting receptacles.

Shell Size	A ± 0.25 (± 6.35)	B ± 0.005 (± 0.13)	C Dia max	J ± 0.005 (± 0.13)
08	3.0 76.2	0.521 13.23	0.892 22.66	0.117 3.03
10	3.0 76.2	0.521 13.23	1.017 22.66	0.119 3.03
12	3.5 88.9	0.521 13.23	1.142 29.01	0.119 3.03
14	3.5 88.9	0.521 13.23	1.267 32.19	0.119 3.03
16	3.5 88.9	0.521 13.23	1.454 36.94	0.119 3.03
18	3.5 88.9	0.521 13.23	1.563 39.70	0.119 3.03
20	4.0 101.6	0.521 13.23	1.687 42.85	0.119 3.03
22	4.0 101.6	0.521 13.23	1.797 45.65	0.119 3.03
24	4.0 101.6	0.556 14.12	1.922 48.82	0.147 3.74

# Accessories

**760**

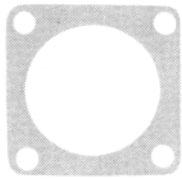

**62GB-760**

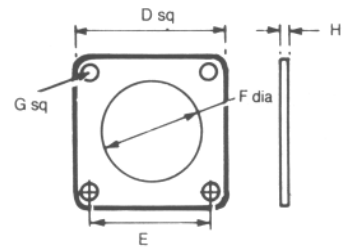









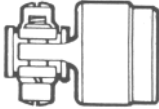

Flange mounting gasket for box mounting and hermetic receptacles.

Shell Size	0 ± 0.010 (± 0.254)	E ± 0.010 (± 0.254)	F ± 0.008 (± 0.20)	G + 0.010 (+ 0.254)	H
08	0.812 20.62	0.594 15.08	0.508 12.90	0.130 3.30	0.042 / 0.016 1.06 / 0.40
10	0.938 23.82	0.719 18.26	0.633 16.07	0.130 3.30	0.042 / 0.016 1.06 / 0.40
12	1.031 26.18	0.813 20.65	0.758 19.25	0.130 3.30	0.042 / 0.016 1.06 / 0.40
14	1.125 28.57	0.906 23.01	0.883 22.42	0.130 3.30	0.042 / 0.016 1.06 / 0.40
16	1.219 30.96	0.969 24.61	1.008 25.60	0.130 3.30	0.042 / 0.016 1.06 / 0.40
18	1.312 33.32	1.063 27.00	1.133 28.77	0.130 3.30	0.042 / 0.016 1.06 / 0.40
20	1.438 36.52	1.156 29.36	1.258 31.95	0.130 3.30	0.042 / 0.016 1.06 / 0.40
22	1.563 39.70	1.250 31.75	1.383 35.13	0.130 3.30	0.042 / 0.016 1.06 / 0.40
24	1.688 42.87	1.375 34.92	1.508 38.30	0.156 3.96	0.042 / 0.016 1.06 / 0.40

# Cable Accessories

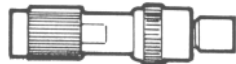
## Table of Styles

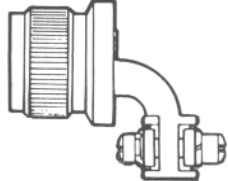
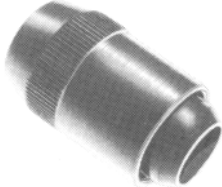
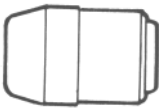

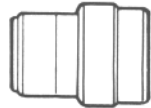
Page No.

62GB-584			51
62GB-585			51
62GB-586			52
62GB-587			52
62GB-711			53
62GB-720			53
62GB-776			54

# Cable Accessories

## Table of Styles

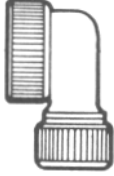
Page No.

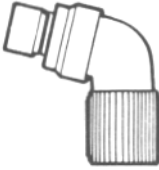
62GB-1225			54
62GB-5028			55

# Cable Accessories

**584**

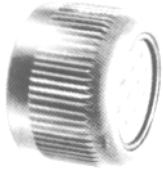

**62GB - 584 - XX - XXS or P**  
BS 9522 FOO 17 A2102

Grommet seal and nut. Provides an environmental seal for the exposed solder buckets in the openback class T shells.

Suffix XX - XXS or P enables grommet to be matched to the insert arrangement.

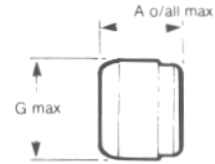

Shell Size	A	G max
08	0.545	0.561
	13.84	14.25
10	0.545	0.686
	13.84	17.43
12	0.545	0.811
	13.84	20.60
14	0.545	0.936
	13.84	23.78
16	0.545	1.061
	13.84	26.95
18	0.545	1.186
	13.84	30.13
20	0.545	1.311
	13.84	33.30
22	0.545	1.436
	13.84	36.75
24	0.501	1.561
	12.73	39.65

**585**



**62G B - 585 - XX - XXS or P**  
BS9522 FOO 17 A2103

Grommet and nut with strain relief clamp. The clamp prevents the flexing of the wires in the immediate vicinity of the risers, so avoiding the risk of leaks.

Suffix XX - XXS or P enables grommet to be matched to the insert arrangement.

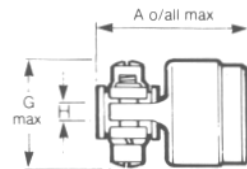

Shell Size	A max	G max	max
08	0.991	0.828	0.161
	25.17	21.03	4.09
10	0.991	0.891	0.193
	25.17	22.63	4.90
12	0.991	1.016	0.317
	25.17	25.81	8.05
14	0.965	1.141	0.380
	24.51	28.98	9.65
16	1.105	1.203	0.505
	28.07	30.56	12.83
18	1.105	1.426	0.630
	28.07	36.22	16.00
20	1.285	1.426	0.630
	32.64	36.22	16.00
22	1.285	1.567	0.755
	32.64	39.80	19.18
24	1.373	1.735	0.805
	34.88	44.07	20.45

# Cable Accessories



**62G B - 586 - XX**

Potting mould and ring, supplied together as a set.

**Suffix XX specifies shell size.**

Shell Size	A max	G max	Z min
08	0.644	0.585	0.260
	16.36	14.85	6.60
10	0.753	0.679	0.463
	19.13	17.24	11.76
12	0.722	0.835	0.557
	18.34	21.20	14.14
14	0.722	0.913	0.590
	18.34	23.19	14.98
16	0.722	1.038	0.713
	18.34	26.36	18.11
18	0.722	1.163	0.835
	18.34	29.54	21.20
20	0.877	1.288	1.015
	22.30	32.71	25.78
22	0.877	1.413	1.015
	22.30	35.89	25.78
24	0.896	1.538	1.263
	22.76	39.06	32.08



**62G B - 587 - XX - XXS or P**

Clamp for screened jacketed cable. 62 Series only with grommet. Effective sealing is provided over the range of cables covered by DEF 10(Pattern C) and DEF STAN 61-12 port (see table). These are supplied to separate order only for use with style T shells.

**Suffix XX-XXS or P enables grommet to be matched to the insert arrangement.**

Shell Size	length Including plug	A Max	length Including receptacle	B max	G max
08	2.732		2.742	0.676	0.775
	69.39		69.64	17.17	19.68
10	2.742		2.752	0.676	0.902
	69.64		69.90	17.17	22.91
12	3.152		3.162	0.812	1.030
	80.06		80.31	20.62	26.16
14	3.152		3.162	0.926	1.157
	80.06		80.31	23.52	29.39
16	3.272		3.282	1.051	1.284
	83.10		83.36	26.67	32.61
18	-		-	-	-
	-		-	-	-
20	3.272		3.345	1.280	1.539
	83.10		84.96	32.51	39.09
22	-		-	-	-
	-		-	-	-
24	3.696		3.768	1.620	1.783
	93.87		95.70	41.15	45.29

# Cable Accessories

**711**



**62G B - 711 - XX - XXS or P**

Grommet and nut with right angled strain relief clamp. The clamp prevents flexing of the wires in the immediate vicinity of the risers, so avoiding the risk of leaks (these are supplied to separate order only for use with style T shells).

**Suffix XX - XXS or P enables grommet to be matched to the insert arrangement.**

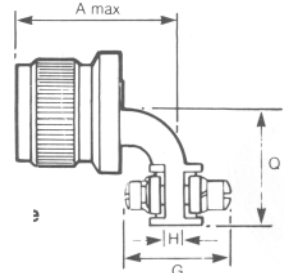

Shell Size	A max	G max	H ± 0.005 ± 0.13	Q max
08	1.5/32	0.828 21.03	0.161 4.09	0.733 18.62
10	1.3/16	0.891 22.63	0.193 4.90	0.795 20.19
12	1.7/32	1.016 25.81	0.317 8.05	0.858 21.79
14	1.1/4	1.141 28.98	0.380 9.65	0.915 23.24
16	1.5/16	1.203 30.56	0.505 12.83	1.010 25.65
18	1.3/8	1.426 36.22	0.630 16.00	1.070 27.18
20	1.3/8	1.426 36.22	0.630 16.00	1.140 28.96
22	1.29/64	1.567 39.80	0.755 19.18	1.170 29.72
24	1.15/32	1.735 44.07	0.805 20.45	1.260 32.00

**720**

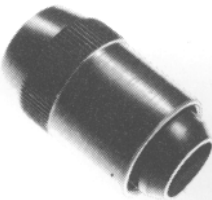

**62G B - 720 - XX**

Clamp for unscreened jacketed cable. No grommet is supplied, for use with 50T, 51T and 56T styles.

**Suffix XX specifies shell size.**

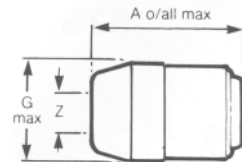

Shell Size	A max	G max	Z closed	Z free
08	1.085 27.56	0.561 14.25	0.168 4.28	0.230 5.84
10	1.060 26.92	0.686 17.43	0.205 5.21	0.312 7.93
12	1.160 29.46	0.811 20.60	0.338 8.59	0.442 11.23
14	1.360 34.54	0.936 23.78	0.416 10.57	0.539 13.69
16	1.585 40.26	1.061 26.95	0.550 13.97	0.616 15.65
18	1.785 45.34	1.186 30.13	0.600 15.24	0.672 17.57
20	1.981 50.32	1.311 33.30	0.635 16.13	0.747 18.98
22	2.181 55.39	1.436 36.75	0.670 17.02	0.846 21.49
24	2.216 56.28	1.561 39.65	0.740 18.80	0.894 22.71



# Cable Accessories

**776**



**62GB - 776**

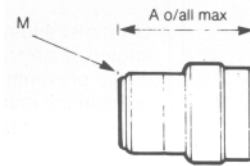

General duty shell to accept conduit, AN 3057 or MS 3057 A cable clamps and heat shrink sleeves.

Shell Size	A max	M Thread
08	0.937 23.80	1/2 - 28 UNEF
10	0.937 23.80	5/8 - 24 NEF
12	0.937 23.80	3/4 - 20 UNEF
14	0.937 23.80	7/8 - 20 UNEF
16	0.937 23.80	1 - 20 UNEF
18	0.937 23.80	1.3/16 - 18 NEF
20	0.937 23.80	1.3/16 - 18 NEF
22	0.937 23.80	1.7/16 - 18 NEF
24	0.937 23.80	1.7/16 - 18 NEF

**1225**

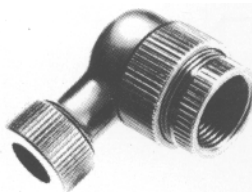

**62GB - 1225**

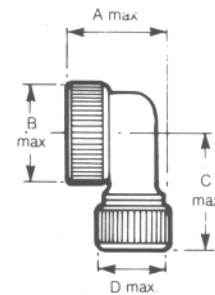

90 clamp for screened jacketed cable. These are supplied to separate order only for use with style T shells.

Shell Size	A max	B max	C max	D max
08	0.942 23.93	0.821 20.85	1.160 29.46	0.636 16.15
10	0.883 22.43	0.821 20.85	1.160 29.46	0.636 16.15
12	0.704 17.88	0.821 20.85	1.160 29.46	0.636 16.15
14	1.119 28.42	0.937 23.80	1.160 29.46	0.636 16.15

# Cable Accessories

**5028**



**62G B - 5028 - XX - XXS or P**

75% Clamp for screened jacketed cable with grommet. Effective sealing is provided over the range of cables covered by DEF 10 (Pattern C) and DEF STAN 61 - 12 part 5 (see table). These are supplied to separate order only and are intended for use with style T shells.

**Suffix XX-XXS or P enables grommet to be matched to the insert arrangement.**

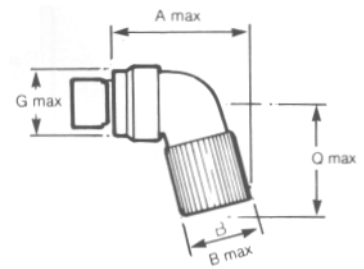

Shell Size	length including receptacle	A Max	length including plug	B max	G max	max
08	2.416		2.375	0.676	0.775	1.750
	61.37		60.24	17.17	19.68	44.45
10	2.573		2.532	0.676	0.902	1.875
	65.35		64.39	17.17	22.91	47.63
12	2.666		2.625	0.812	1.030	2.125
	67.72		66.68	20.62	26.16	53.98
14	2.760		2.719	0.926	1.157	2.125
	70.10		69.04	23.52	29.39	53.98
16	2.790		2.750	1.051	1.284	2.062
	70.87		69.80	26.70	32.61	52.38
18	-	-	-	-	-	-
20	3.312		3.250	1.280	1.539	2.062
	84.13		82.55	32.51	39.09	52.38
22	-	-	-	-	-	-
24	3.500		3.375	1.620	1.783	2.187
	88.90		85.73	41.15	45.29	55.55

# Insert Orientations

For M I L-C-26482 and for replacement purposes in BS9522 FOO 17

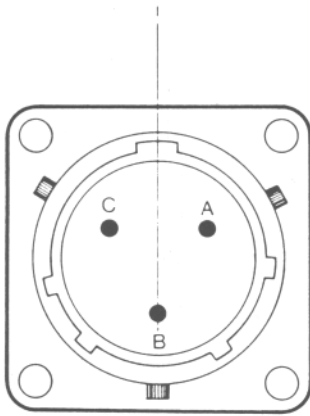

Normal position with pin contacts

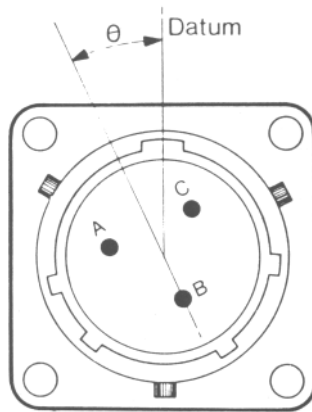

Alternative position of insert with socket contacts ( $\varnothing$  counterclockwise)

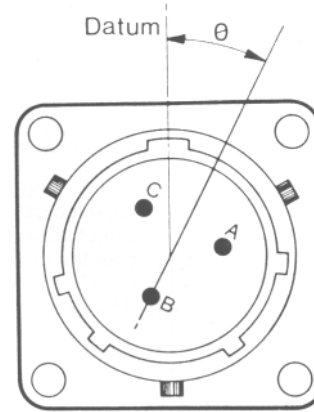

Alternate position of insert with pin contacts ( $\varnothing$  clockwise)

Each diagram shows mating face of insert.

Insert Arrangement	Normal	Orientation $\varnothing$ (degrees)			Z
		W	X	Y	
8-2	0	58	122	-	-
8-3	0	60	210	-	-
8-33	0	90	-	-	-
8-4	0	45	-	-	-
8-98	0	-	-	-	-
10-2	0	-	-	-	-
10-6	0	90	-	-	-
10-7	0	-	-	-	-
12-3	0	-	-	180	-
12-10	0	60	155	270	295
14-5	0	40	92	184	273
14-12	0	43	90	-	-
14-15	0	17	110	155	234
14-19	0	30	165	315	-
16-18	0	54	152	180	331
16-23	0	158	270	-	-
16-26	0	60	-	275	338
18-11	0	62	119	241	340
18-32	0	85	138	222	265
20-16	0	238	318	333	347
20-41	0	45	126	225	-
22-21	0	16	135	175	349
22-55	0	30	142	226	314
24-61	0	90	180	270	324

# Key/Keyway Orientations

## For BS9522 F0017

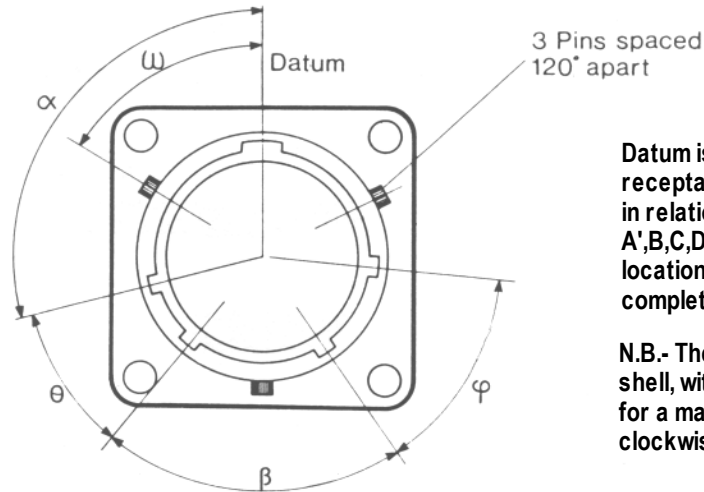

Datum is always taken from major key or keyway. In receptacles the major keyway always remains fixed in relation to the mounting flange. For the A',B,C,D',E and F orientations, the three bayonet locations and associated minor keyways are rotated complete, in accordance with the table below.

N.B.- The accompanying diagram shows a receptacle shell, with keyways. Corresponding key orientations for a mating plug shell are therefore always clockwise.

Shell Size	Values for $\infty$ (degrees)						Values for $\theta$ (degrees)						Values for $\beta$ (degrees)								
	N	A*	B	C	D*	E	F	N	A*	B	C	D*	E	F	N	A*	B	C	D*	E	F
8	105	92	-	-	118	118	82	35	35	-	-	35	30	50	75	75'	-	-	75	100	75
10	105	95	85	125	115	115	85	35	35	35	35	35	30	50	75	75	75	75	75	100	75
12	105	97	89	121	113	115	85	35	35	35	35	35	30	50	75	75	75	75	75	100	75
14	105	98	91	119	112	75	120	35	35	35	35	35	30	50	75	75	75	75	75	100	75
16	105	99	93	117	111	75	120	35	35	35	35	35	30	50	75	75	75	75	75	100	75
18	105	100	95	115	110	75	120	35	35	35	35	35	30	50	75	75	75	75	75	100	75
20	105	100	95	115	110	75	120	35	35	35	35	35	30	50	75	75	75	75	75	100	75
22	105	101	97	113	109	75	120	35	35	35	35	35	30	50	75	75	75	100	75	75	75
24	105	101	97	113	109	75	120	35	35	35	35	35	30	50	75	75	75	75	75	100	75

Shell Size	Values for $\phi$ (degrees)							Values for $\omega$ (degrees)						
	Orientation							Orientation						
	N	A*	B	C	D*	E	F	N	A*	B	C	D*	E	F
8	50	50	50	50	50	30	45	60	47	-	-	73	73	47
10	50	50	50	50	50	30	45	60	50	40	80	70	70	50
12	50	50	50	50	50	30	45	60	52	44	76	68	70	50
14	50	50	50	50	50	30	35	60	53	46	74	67	30	75
16	50	50	50	50	50	30	35	60	54	48	72	66	30	75
18	50	50	50	50	50	30	35	60	55	50	70	65	30	75
20	50	50	50	50	50	30	35	60	55	50	70	65	30	75
22	50	50	50	50	50	30	35	60	56	52	68	64	30	75
24	50	50	50	50	50	30	35	60	56	52	68	64	30	75

\* now inactive for new designs but available for replacement purposes. Superseded in BS9522 F0017 by orientations E and F.